

To users of our inverters: Our inverters are designed to control the speeds of three-phase induction motors for general industry.

Precautions

- * Read the instruction manual before installing or operating the inverter unit and store it in a safe place for reference.
- * When using our inverters for equipment such as nuclear power control equipment, aviation and space flight control equipment, traffic equipment, and safety equipment, and there is a risk that any failure or malfunction of the inverter could directly endanger human life or cause injury, please contact our headquarters, branch, or office printed on the front and back covers of this catalogue. Such applications must be studied carefully.
- * When using our inverters for critical equipment, even though the inverters are manufactured under strict quality control always fit your equipment with safety devices to prevent serious accident or loss should the inverter fail (such as failure to issue an inverter trouble signal).
- * Do not use our inverters for any load other than three-phase induction motors.
- * None of Toshiba, its subsidiaries, affiliates or agents, shall be liable for any physical damages, including, without limitation, malfunction, anomaly, breakdown or any other problem that may occur to any apparatus in which the Toshiba inverter is incorporated or to any equipment that is used in combination with the Toshiba inverter. Nor shall Toshiba, its subsidiaries, affiliates or agents be liable for any compensatory damages resulting from such utilization, including compensation for special, indirect, incidental, consequential, punitive or exemplary damages, or for loss of profit, income or data, even if the user has been advised or apprised of the likelihood of the occurrence of such loss or damages.

For further information, please contact your nearest Toshiba Representative or International Operations-Producer Goods.
The information in this brochure is subject to change without notice.



200V class 18.5~110kW
400V class 18.5~315kW

VF-P7 has same engine with high performance inverter VF-A7.

The control engine including unique sensorless vector control and rich parameters is full compatible with VF-A7.
 Difference is only maximum current capability (VF-P7:120%, VF-A7:150%).
 VF-P7 can drive even heavy load (constant torque), in case peak torque is limited. (ex. winder, re-winder)



UKAS
QUALITY
MANAGEMENT
001

JAB
QS Accreditation
R. 016

ISO 9001
 VF-P7 series is designed and manufactured at the Works, which received the international quality assurance standard ISO 9001.

ISO 14001
ENVIRONMENTAL
MANAGEMENT
SYSTEMS

JAB
EMS Accreditation
REC009

ISO 14001
 The Works producing VF-P7 series is registered as an environment management system factory specified by ISO 14001.

CE Marking
 The installation of a Toshiba-recommended optional filter makes every Toshiba VF-P7 inverter fully compliant with EMC directives and low-voltage directives. For more information, refer to the instruction manual.



N1971
 Scheduled to support these standards in the near future

Models and applicable motors *The VF-S11 series is available for motors with outputs of 15kW and smaller. For more information, please refer to the catalog for VF-S11 series inverters.

Input voltage (three-phase 200V output)	Outputs of applicable motors (kW)																								
	0.2	0.4	0.75	1.5	2.2	3.7	5.5	7.5	11	15	18.5	22	30	37	45	55	75	90	110	132	160	200	220	280	315
Single-phase 200V class	VF-S11series																								
Three-phase 200V class	VF-S11series											VF-P7series													
Three-phase 400V class	VF-S11series											VF-P7series													

1 VF-P7 saves energy, automatic energy saving mode saves even more

By using the VF-P7 in conjunction with a fan or pump to control its air volume or discharge, you can save a considerable amount of energy, as compared to control by a damper. Using the automatic energy saving mode saves even more energy.

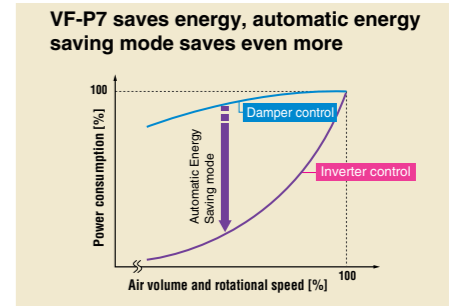

2 Simple selection and use

- On/Off control of the cooling fan ensures longer life.
- Same operating method as the VF-A7 and-S11 series enables use with the same optional units.
 - The VF-S11 series is available for motors with outputs of 15kW and smaller. For more information, refer to the catalog for VF-S11 series inverters.
 - Easy operation common to VF-A7 and-S11 series inverters.
 - Parameters common to VF-A7 and-S11 series inverters. This means that, if you are using VF-A7 and-S11 series inverter, you can easily replace it with any other VF-A7 and-S11 series inverter. In addition, optional extension panels and parameter writer be used with VF-A7 and-S11 series inverters.
 - Serial options can be used with VF-A7 and-S11 series inverters.
- Fin can be attached externally. (Optional for 200V 18.5 to 30kW models and 400V 18.5 to 37kW models)
- If operated in Constant Torque mode, the VF-P7 can be used as a generalpurpose inverter. (Overload current rating : 120%-1min)

3 Full range of functions for fans and pumps

- Automatic energy saving function
Ensures efficient energy saving by limiting the current to the motor.
- Momentary Power failure measures
The auto-restart function smoothly restarts the coasting motor to recover from a momentary power failure. In Ride-Through Control mode, the VF-P7 allows the machine to keep running on regenerative energy produced by the motor in case of a momentary power failure.
Note: Depending on the inertia or loading conditions, it can sometimes be difficult for the machine to keep operating in case of a momentary power failure.
- Commercial Power/Inverter switching circuit
There is no need to install a time relay or equivalent outside. The inverter has a sequence to switch them.
- PID control
Standard PID control function designed for process control of air volume, discharge, pressure, etc.
- Preset-speed operation
You can select a maximum of 15 speeds by simply switching contacts from outside.
- Monitoring item switching function (allows you to switch information displayed with the power on)
You can switch information displayed from the frequency to the current or other items.
- Control circuit I/O logic (Sink/Source) switching function
This function enables to easily switch the control circuit I/O logic (between Sink and Source). You can easily connect various types of programmable controllers.

4 Security when something goes wrong

- Soft stall
If the VF-P7 detects an overload, it automatically reduces the output frequency before the machine trips. Even under overload, the VF-P7 allows the machine to keep running without tripping at a frequency corresponding to the load current.
- Retry function
If a protective function is activated, the VF-P7 tries to restart the machine a maximum of 10 times after checking the main circuit elements.
- Low-current detection
This function enable to prevent machine from idling.
- Its many protective functions ensure safe operation
 - The VF-P7 has an I/O open phase detecting function and a ground fault detecting function.
 - The VF-P7 allows the machine to continue operation in case of a voltage drop (+10%, -15%).
 - Even if the input voltage fluctuates, the VF-P7 keeps the V/f ratio constant by correcting the supply voltage.
 - The VF-P7 allows you to adjust the electronic thermal characteristic and the motor 150%-overload withstanding time according to the performance of the machine. This feature is very useful especially when the VF-P7 is used with machines that need to be stopped immediately if they become overloaded.

Contents

Applications	3
Panel description	5
Panel operation	6
Standard specifications	7
External dimensions	9
Selection of wiring equipment	10
Standard connection	11
Description of terminal functions	12
Basic and extended parameters	13
Protections	16
To users of our inverters	17
Application and functions of options	20
Add-on module/board type options	21

VF-P7 has a wide range of applications

Air volume (temperature) control for fans, ventilators, blowers, etc.

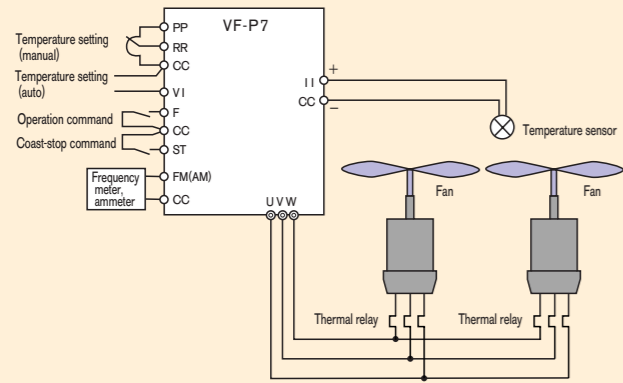

Function	Related parameter
Keeps the fan running as long as possible in the event of a momentary power failure. If the fan stops running due to a momentary power failure, the inverter automatically restarts it immediately after recovery from the power failure.	Ride-through control: F302 Auto-restart: F301
Restarts the motor without bringing it to a stop even if the fan is coasting. If needed, the VF-P7 automatically switches between commercial power operation and inverter operation.	Motor speed search (auto-restart): F301
Automatically restart after tripping.	Retry selection: F303 (10 times maximum)
Continues operation without tripping at overload.	Overload stall selection: OLN , Stall level setting: F601 Acceleration/deceleration time setting: ACC, DEC, F500 to F517
Puts out a signal when an overload is detected.	Over-torque detection: F615 to F618
Allows you to set a lower-limit rotational speed to prevent the fan from rotating in reverse direction.	Lower-limit frequency setting: LL
Lets the fan coast stop.	ST signal selection: F103 , Input terminal selection: F111 to F118 = 6 (one function selectable)
Detects low currents to prevent idling.	Low-current detection: F610 to F612
Operates the fan, etc. so that it does not resonate with the machine.	Jump frequency: F270 to F275
Allows you to check the rotational speed and load of the fan by means of external meters.	Meter output (FM, AM, FP and optional terminals): FASL , F670 to F680
Allows you to switch the display from frequency to another (switching information displayed with the power on).	Monitor display mode selection: F710
Ensures stable operation even if the supply voltage fluctuates.	Supply voltage correction and output voltage limit: F306 and F307
Allows energy-saving operation.	V/f control selection: P2 = 4 or 5
Other protective functions	Cooling fan control selection: F620 , Cumulative operation timer alarm: F621 , Undervoltage trip: F627 to F628 , Output short circuit detection: F613 to F614

Function	Related parameter
Controls the temperature or humidity by regulating the rotational speed of the fan. The VF-P7 is capable of controlling multiple fans, ventilators, or blowers.	PID control selection: F360 , PID constant adjustment: F361 to F366
Switches between manual and automatic operation modes (switches between two setting signals).	Rotational speed priority selection: F200 , F201 and F208
Switches from inverter operation to commercial power operation in case the inverter fails.	Commercial power/inverter switching: F354 = 1, 3 Switching constant: F355 to F358

Winder Re-winder control (speed/torque control with PG feedback)

Function	Related parameter
To drive constant torque application with high accurate speed and torque, PG feedback is required. With this, holding torque also can be generated.	Motor control mode: P2 = 0, 2, 7, 8 or 3 Motor tuning: F400 to F414 PG feedback: F367 , F368 , F369
For simple machine which does not need accuracy, sensorless vector control is available.	Speed control with PG: F376 , F377 Torque control: F420 to F451
Depending on machine, VF-P7 can control speed or torque. They are switchable by an external signal.	Speed / Torque control switch mode: P2 = 7 or 8 , Speed / Torque control switch input: F115 (S1) = 112 (113)
For regeneration operation, a braking resistor (up to 22kW), a braking resistor unit (30kW or more) or equivalent unit is required.	Braking resistor operation: F304 = 1 , F308 , F309

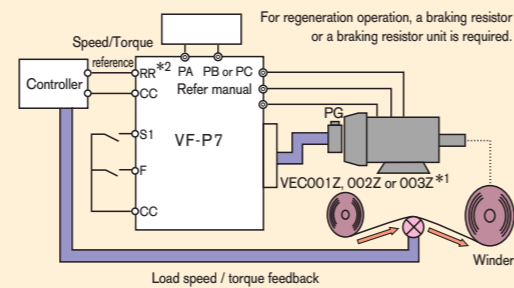

Note: * 1) For PG feedback control, one of our option VEC001Z, 002Z or 003Z is required.
* 2) RX terminal has capability to accept bipolar voltage reference. (RR terminal is only for monopolar.)

Cooling water temperature control for cooling towers

Function	Related parameter
Detects the cooling water temperature with a temperature sensor and keeps it constant by PID control.	PID control selection: F360 , PID constant adjustment: F361 to F366
Reduces the rotational speed of the fan at night for noise reduction.	PID control OFF selection: F118 (S4 terminal) = 36 (37) Rotational speed (frequency) commands 1) Application of currents of 4 to 20mA : F20d = 1 2) Application of voltages of 0 to 10V, potentiometer : F20d = 2 3) Panel setting : F20d = 5 4) Communications : F20d = 6, 7 and 8
Automatically switches from inverter operation to commercial power operation, using the backup switching function, if the inverter fails.	Commercial power/inverter switching: F354 = 1, 3 Switching constant: F355 to F358

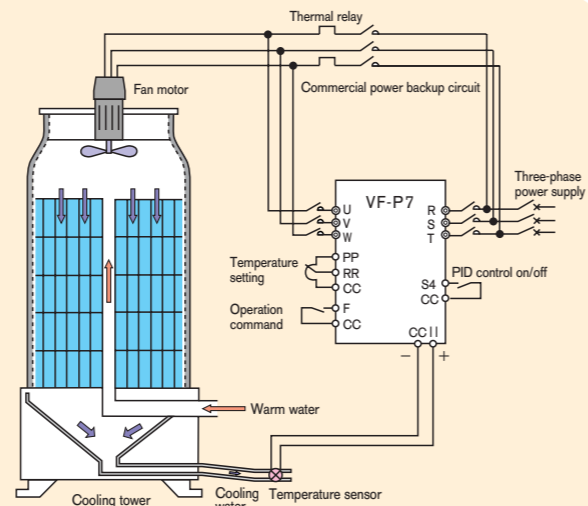

Rotational speed control for agitators

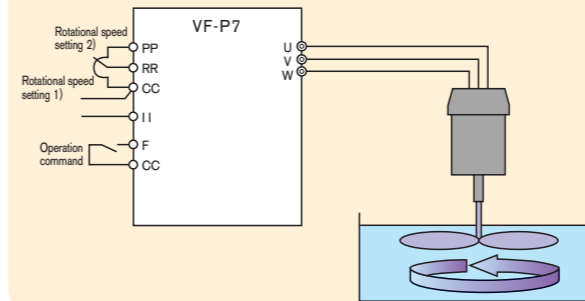

Function	Related parameter
Regulates the rotational speed according to the viscosity of the liquid to be agitated.	Rotational speed (frequency) commands 1) Application of currents of 4 to 20mA : F20d = 1 2) Application of voltages of 0 to 10V, potentiometer : F20d = 2 3) Panel setting : F20d = 5 4) Communications : F20d = 6, 7 and 8

Note: If you want to use the VF-P7 in conjunction with an explosion-proof motor in a location where chemicals are used, consult us beforehand.

Operating a single pump

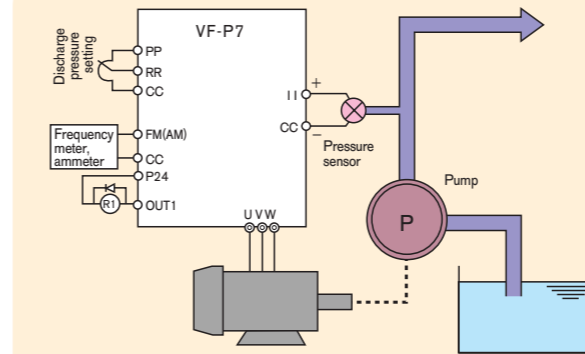

Function	Related parameter
Keeps the pressure, water level, etc. constant.	PID control selection: F360 , PID constant adjustment: F361 to F366
Switches between manual and automatic operation modes (switches between two setting signals).	Rotational speed priority selection: F200 , F201 and F208
Switches to commercial power operation in case the inverter fails. Also, the VF-P7 allows you to switch manually between inverter operation and commercial power operation.	Motor speed search (auto-restart): F301 Commercial power/inverter switching: F354 , Switching constant: F355 to F358

Function	Related parameter
Restarts the motor immediately after recovery from a momentary power failure.	Auto-restart: F301
Continues operation without tripping at overload.	Overload stall selection: OLN , Stall level setting: F601 Acceleration/deceleration time setting: ACC, DEC, F500 to F517
Puts out a signal when an overload is detected.	Over-torque detection: F615 to F618
Stops the motor immediately if it becomes overloaded.	Motor overload withstanding time: F607
Sets a lower-limit rotating speed to prevent fluid from flowing in reverse direction.	Lower-limit frequency setting: LL
Detects low currents to prevent idling.	Low current detection: F610 to F612
Automatically recovers from a trip.	Retry selection: F303 (10 times maximum)
Allows you to check the rotational speed and load of the pump by means of external meters.	Meter output (FM, AM, FP, optional terminals) FASL , F670 to F680
Allows you to switch the display from the frequency to another (switching information displayed with the power on).	Monitor display mode selection: F710
Ensures stable operation even if the supply voltage fluctuates.	Supply voltage correction and output voltage adjustment: F306 and F307
Allows energy-saving operation.	V/f control selection: P2 = 4 or 5
Other protective functions	Cooling fan control selection: F620 Cumulative run timer alarm: F621 Undervoltage trip: F627 to F628 Output short circuit detection: F613 to F614

Control to keep the water level constant

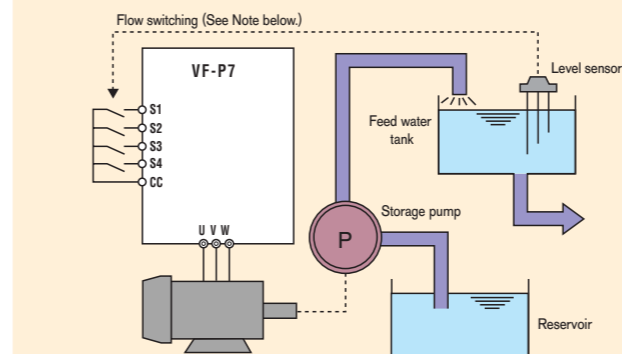

Function	Related parameter
According to the signal from the level sensor or flow sensor, a flow switching command is issued to the VF-P7 to keep the water level or flow rate constant.	Flow switching (preset-speed operation): Sr = 1 to Sr = 7 , F287 to F294

Note: Signals (0 to 10Vdc, 4 to 20mA) from the level sensor can also be used to keep the water level constant by PID control.

Operating multiple pumps in parallel if the discharge pressure does not increase to a specified level

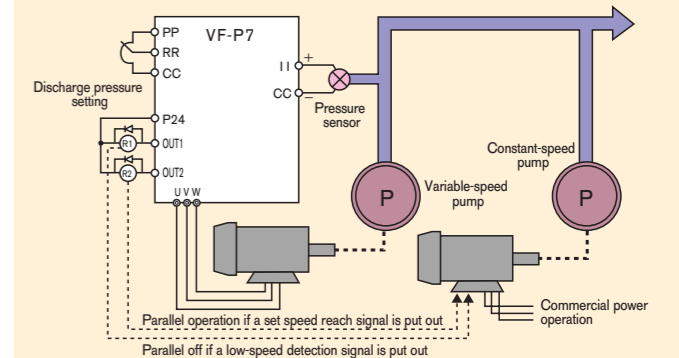

Function	Related parameter
If the discharge pressure of the variable-speed pump does not reach the specified level though the pump runs at the maximum frequency, the constant-speed pump starts by set speed reach signal to operate the two pumps in parallel.	Output terminal selection: F131 (OUT2) = 8 (5) (set speed reach signal) Speed reach setting frequency: F101 to F102
Cuts off the constant-speed pump by putting out a low-speed detection signal.	Output terminal selection: F130 (OUT1) = 4 (5) (low-speed detection signal) Low-speed frequency: F100

Panel description — Name and functions

VEC lamp
Lit when the inverter is in vector control mode.

ECN lamp
Lit when the inverter is in energy-saving mode.

RUN key lamp
Lit when the RUN key is enabled.

RUN key
Pressing this key while the RUN key lamp is lit starts the motor.

UP/DOWN key lamp
With UP/DOWN keys, you can set the operation frequency while this lamp is lit.

RUN lamp
Lit when the inverter is in operation or blinks when it is in auto acceleration/deceleration mode.

MON lamp
Lit when the inverter is in monitor mode.

PRG lamp
Lit when the inverter is in parameter setting mode.

STOP key
Pressing this key while the RUN key lamp is blinking causes the motor to make a slowdown stop.

MONITOR key
Pressing this key displays the operation frequency, parameter setting, error messages, and so on.

ENTER key
Press this key to read and write parameters, data, frequency and so on.

DOWN key

UP key

CHARGE lamp
Indicates that a high voltage remains in the inverter. Do not open the terminal board cover for safety while this lamp is lit.

Cover for common serial option connectors
To use connectors reserved for options, detach this cover by sliding it to the right.
· Parameter writer
· Extension panel
· RS232C/RS485 with terminal board

Cover for serial RS485 connectors
To use an RS485 connector, detach this cover by sliding it to the right.

Optional add-on cassettes (optional boards)
Used to install the following options:
· Extended terminal board(ETB001Z)
· Sensor vector control-compatible options* (VEC001Z)
· TOSLINE-F10M option(TLF001Z)
· TOSLINE-S20 option(TLS001Z), etc.

* Optional boards : VEC002Z
VEC003Z
Under the terminal board front cover
Note) Use an attachment for mounting add-on cassette options.

Sink/source switching

Panel operation

Operation

- Turn on the power. 0.0 is displayed.
- The frequency changes.
- The frequency selected is saved. FC and the frequency are displayed alternately.
- The inverter starts operation. The frequency increases to the specified frequency in the specified acceleration time.
- The machine slows down and comes to a stop. The machine comes to a full stop in the specified deceleration time.

Setting

- Turn on the power. 0.0 is displayed.
- RU 1 is displayed on the monitor.
- ACC is displayed.
- F300 is displayed.
- F304 is displayed.
- The current setting is displayed.
- F304 and the value you selected are displayed alternately. The setting is now complete.

Monitoring

- The operation frequency is displayed (ex. during operation).
- The direction of rotation is displayed.
- The operation frequency is displayed again. (Returns to the initial item.)

Basic parameter setting
Ex.) Setting an acceleration time

Press and hold down the key until ACC is displayed on the monitor.

extended parameter Setting
Ex.) Selecting the dynamic braking mode

Press and hold down the key until F3-- is displayed on the monitor.

Operation frequency command	60.0
Load current	C 80
Input voltage	Y 100
Output voltage	P 100
Input terminal information 1	111111
Input terminal information 2 (optional)	A 1111
Input terminal information 3 (optional)	b 1111
Output terminal information 1	111
Output terminal information 2 (optional)	0 111
Output terminal information 3 (optional)	P 1111
Sink/source switching status	L 0
Types of connected options	0 0
EYP last monitoring	t 0
RU2 last monitoring	A 0
CPU version	v 120
Flash memory version	F 100
Control E'PROM version	E 0
Drive E'PROM version	d 100
Past trip 1	OC3 ⇄ 1
Past trip 2	OH ⇄ 2
Past trip 3	OP3 ⇄ 3
Past trip 4	nErr ⇄ 4
Cumulative operation time	t 0.1
Direction of rotation	Fr - F

To operate the machine from the operation panel, it is necessary to specify the following parameters beforehand.

CNOd = 1 (operation panel input enabled)

FNOd = 5 (operation panel input enabled)

Standard specifications

Model and standard specifications

200V series

item		Standard specification									
Input Voltage		200V class									
Applicable motor (kW)		18.5	22	30	37	45	55	75	90	110	
Rating	Type	VFP7-									
	Model	2185P	2220P	2300P	2370P	2450P	2550P	2750P	2900P	2110KP	
	Capacity (kVA)*1	28	34	46	55	69	84	110	133	160	
	Rated output current (A)	73	88	120	144	180	220	288	350	420	
	Rated output voltage	3-phase 200 to 230V (The max. output voltage is the same as the input power supply voltage.)									
Overload current rating		1 minute at 120% , 0.5 seconds at 180%						1 minute at 120% , 0.3 seconds at 150%			
Electrical braking	Dynamic braking circuit	Dynamic braking circuit installed			Optional						
	Dynamic braking resistor	External braking resistor (optional)									
Input Power	Voltage/ Frequency	Main circuit	3-phase 200 to 220V - 50Hz , 200 to 230V - 60Hz						3-phase 200 to 230V - 50/60Hz		
		Control circuit*2	External circuit (optional)			Single-phase 200 to 220V - 50Hz 200 to 230V - 60Hz			Single-phase 200 to 230V - 50/60Hz		
	Tolerance	Voltage +10/-15% *5 , frequency ± 5%									
Protective method		Enclosed type (JEM1030)IP20*3			Open structure (JEM1030)IP00*4						
Cooling method		Forced air cooling									
Color		Munsell 5Y-8/0.5									

400V series

item		Standard specification																
Input voltage		400V class																
Applicable motor (kW)		18.5	22	30	37	45	55	75	90	110	132	160	200	220	280	315		
Rating	Type	VFP7-																
	Model	4185P	4220P	4300P	4370P	4450P	4550P	4750P	4900P	4110KP	4132KP	4180KP	4200KP	4220KP	4280KP	4315KP		
	Capacity (kVA)	28	34	46	55	69	84	110	143	160	194	236	300	320	412	470		
	Rated output current (A)	37	44	60	72	90	110	144	180	210	255	310	377	420	540	590		
	Rated output voltage	3phase 380 to 460V (The max. output voltage is the same as the input power supply voltage.)																
Overload current rating		1 minute at 120% , 0.5 seconds at 180%								1 minute at 120% , 0.3 seconds at 150%								
Electrical braking	Dynamic braking circuit	Dynamic braking circuit installed			Optional													
	Dynamic braking resistor	External braking resistor (optional)																
Input Power	Voltage/ frequency	Main circuit	3-phase 380 to 460V - 50/60Hz				3-phase 380 to 440V - 50Hz 380 to 460V - 60Hz				3-phase 380 to 460V - 50/60Hz							
		Control circuit*2	External circuit (optional)			Single - phase 380 to 440V - 50Hz 380 to 460V - 60Hz				Single - phase 380 to 460 - 50/60Hz								
	Tolerance	Voltage +10/-15% *5 , frequency ± 5%																
Protective method		Enclosed type (JEM1030)IP20*3				Open structure (JEM1030)IP00*4												
Cooling method		Forced air cooling																
Color		Munsell 5Y-8/0.5																

Notes) *1: Capacity is calculated at 220V for the 200V models and at 440V for the 400V models

*2: An option is required for the 22kW and smaller models to be compatible with the control power supply (RO or SO).

*3: Each model has three through-holes for wiring of the main input circuit, main output circuit and control circuit. Seal them properly after wiring.

*4: The models with a capacity of 30kW or more have uncovered wide-opened wiring holes and the unit has no space in it which is large enough to bend external cables. So, use an optional wiring hole cover when installing the unit outside.

*5: ± 10% when the inverter is used continuously (load of 100%)

*6: Be sure to install a DC reactor(DCL) for the 200V 75kW and larger models or 400V 110kW and larger models.

General specifications

Item	Standard specification		
Control method	Sinusoidal PWM control		
Output voltage adjustment	Main circuit voltage feedback control (Automatic regulation, "fixed" and "control off" selections possible)		
Output frequency range	0.01 to 400Hz, set to 0.01 to 80Hz by default, max. frequency adjustable from 30 to 400Hz		
Frequency setting resolution	0.01Hz: operation panel input (60Hz base), 0.015Hz: analog input (60Hz base, 12/0-10Vdc)		
Frequency precision	± 0.2% of the max. output frequency (25±10°C): analog input, ± 0.01% (25±10°C): digital input		
Voltage/frequency characteristic	Constant V/f, variable torque, automatic torque boost, vector control and automatic energy-saving control, base frequency 1·2·3·4 adjustment (25 to 400Hz) arbitrary V/f 5-point settings, torque boost adjustment (0 to 30%), start-up frequency adjustment (0 to 10Hz), end frequency adjustment (0 to 30Hz)		
Frequency setting signal	3kΩ potentiometer (1 to 10kΩ-potentiometer connection also possible), 0 to 10Vdc (input impedance Zin: 33kΩ), 0 to ±10Vdc (Zin: 69kΩ), 4 to 20mAdc (Zin: 500Ω)		
Terminal board reference frequency input	A characteristic can be selected by specifying two reference points. Applicable to a total of 6 kinds of input: analog input (RR, VI, II, RX and RX2), pulse input and binary/BCD input. (*RX2 and binary/BCD: optional)		
Frequency jump	Can be set in three places, jump frequency and band setting		
Upper/lower limit frequencies	Upper limit frequency: 0 to maximum frequency, lower limit frequency: 0 to upper limit frequency		
PWM carrier frequency selections	Adjustable within a range of 0.5 to 15kHz (0.5 to 5kHz for 200V 75kW or larger models and 400V 110kW or larger models)		
PID control	Proportional gain, integral time, rate time, filter delay adjustments		
Acceleration/deceleration time	0.01 to 6000 sec., acceleration/deceleration time selectable from among 1, 2, 3 and 4, automatic acceleration/deceleration function, S-pattern acceleration/deceleration patterns 1 and 2 adjustment		
DC injection braking	Braking start frequency adjustment (0 to 120Hz), braking current adjustment (0 to 100%), braking time adjustment (0 to 10 sec.), emergency stop braking function, motor shaft stationally control function		
Forward/reverse run *1	Forward run F-CC "closed", reverse when R-CC "closed", reverse when both "closed", coast stop when ST-CC "opened", emergency stop from panel or terminal block		
Jog run *1	Jog run from panel with JOG mode selection. Terminal block operation possible with parameter settings.		
Preset-speed operation *1	Set frequency +15-speed preset operations possible with open/close combinations of S1, S2,S3, S4 and CC. Acceleration/deceleration time, torque limit and V/f selectable on a frequency		
Retry	If a protective function is activated, the inverter checks the main circuit elements and tries to restart operation. Number of times of retry: 10 times maximum.		
Soft-stall	Automatic load reduction control during overload (Default setting: OFF)		
Cooling fan ON/OFF	If not required, the cooling fan is automatically stopped to prolong its life.		
Panel key operation ON/OFF switching	Function of disabling keys on the operation panel. Keys, such as the STOP key and the MON key, can be disabled individually. It is also possible to disable all keys.		
Regenerative power ride-through control	Operation is continued even during momentary power failure using regenerative energy from the motor. (Default setting: OFF)		
Auto-restart	The motor can be restarted at the same speed in the same direction as under no-load conditions before stop. (Default setting: OFF)		
Commercial power/inverter switching	Power supply to motor, switchable between commercial power and inverter		
Override function	Preset frequency control value adjustable by signals from an external control unit		
Protective function	Stall prevention, current limit, overcurrent, overvoltage, load-side short-circuit, load-side ground fault, undervoltage, momentary power failure (15ms or longer), regeneration power ride-through control, electronic thermal overload protection, armature overcurrent during start-up, load-side overcurrent during start-up, dynamic braking resistor overcurrent/overload, heat sink overheat, emergency stop		
Electronic thermal characteristic	Standard motor/constant-torque VF motor switching, electronic thermal stall prevention operational level adjustment		
Reset	Reset triggered by closing 1a-contact (or opening 1b-contact), by control panel operation, or by turning on the power after turning off temporarily. Tripped state retention and clear settings		
Display functions	4-digit 7-segment LED	Warning message	Stall prevention during operation, overcurrent suppression, overload, power source-side undervoltage , DC circuit undervoltage, setting error, retry in process, upper/lower limits
		Fault causes	Overcurrent, overvoltage, heat sink overheat, load-side short-circuit, load-side ground fault, inverter overload, armature overcurrent during start-up, load-side overcurrent during start-up, EEPROM error, RAM error, ROM error, transfer error (dynamic braking resistor overcurrent/overload), (emergency stop), (undervoltage), (weak current), (overtorque), (motor overload), (output open-phase). Items in parentheses are selectable.
	Monitoring function		Operation frequency, operation frequency command, operating direction (forward/reverse), output current, DC voltage, output voltage, compensated frequency, terminal board input /output information, CPU version, control EEPROM version, tripping history, cumulative operation time, speed feedback, torque, torque command, torque current, exciting current, PID feedback value, motor overload rate, inverter overload rate, PBR overload rate, PBR load rate, power supply, output power, peak output current, peak DC voltage, motor counter pseudo PG, position pulse, R/R input, V/II input, RX input, RX2 input, FM output, AM output, fixed output for meter adjustment, flash memory version, main circuit EEPROM version, connection option types, previous default setting, previous automatic control (AU2), sink/source switching status
		Selectable unit display	Display of any given unit other than output frequency (e.g., rotational speed and line speed), switching current between in amperes and %, voltage between in volts and %
	Edit function	Parameters different from those set by default are retrieved automatically, so that parameters changed can be detected easily.	
	User settings initialization	Original parameters set by user can be stored. Parameters stored can be reset to original user-defined parameters.	
LED	Charge indicator	Indicates that main circuit capacitors are charged.	
I/O terminal input function	Either positive logic or negative logic can be selected from the programmable I/O terminal function menu. *1,2 (All I/O terminals are factory-set to positive logic.)		
Sink/source switching	Common control terminal switchable between minus (CC) and plus (P24) (Default setting: minus common(CC))		
Output signals	Fault detection signal	1c - contact output (250Vac-2A-cosφ = 1, 250Vac-1A-cosφ = 0.4, 30Vdc-1A)	
	Low-speed/speed reach signal output *2	Open-collector output (24Vdc, Max. 50mA, output impedance: 33Ω)	
	Upper/lower limit frequency output *2	Open-collector output (24Vdc, Max. 50mA, output impedance: 33Ω)	
	Frequency meter output/ammeter output *3	Analog output, 1mAdc full-scale ammeter or 7.5Vdc-1mA voltmeter	
Pulse train frequency output	Open-collector output (24Vdc, Max. 50mA)		
Communication functions	RS485 equipped as standard (connector: modular 8P, optional device required for communication with more than one unit) RS232C , TOSLINE-F10M and TOSLINE-S20 are optional.		
Service conditions	Service environment	Indoor, altitude 1000m or less, not subject to direct sunlight or corrosive/explosive gas or steam	
	Ambient temperature	-10 to +50°C	
	Storage temperature	-25 to +65°C	
	Relative humidity	20 to 90% (no condensation allowed)	
	Vibration	5.9m/s ² or less (10 to 55Hz) (according to JIS C0040)	

Notes)

*1: The 16 contact-input terminals (8 of which are optional) are programmable. For each of them, a signal can be selected from among 136 signals.

*2: For each programmable ON/OFF output terminal, a signal can be selected from among 120 signals.

*3: For each programmable analog output terminal, a signal can be selected from among 33 signals.

External dimensions

Outline drawing

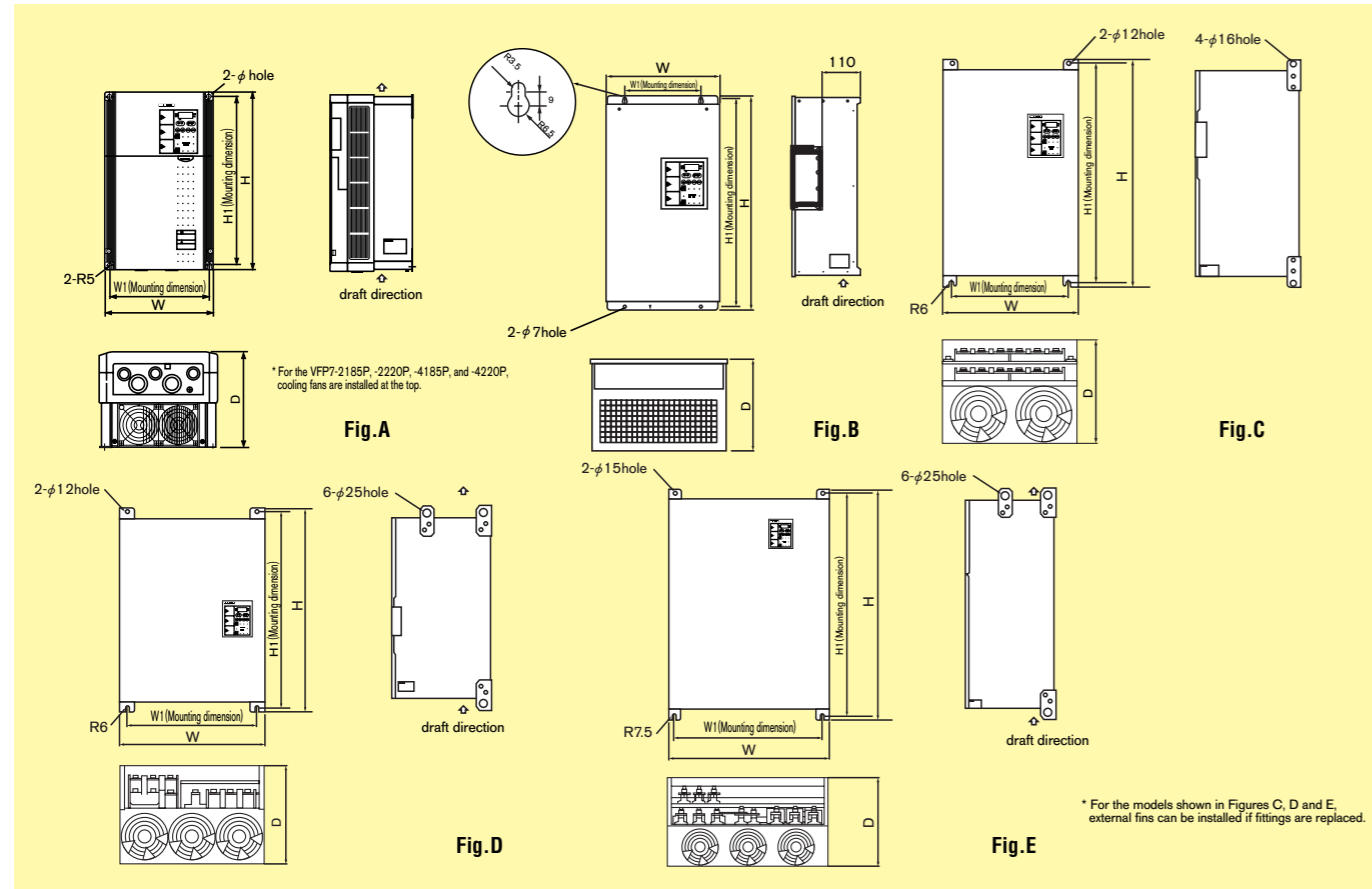

External dimensions/weights

Voltage class	Applicable motor capacity (kW)	Inverter type	Dimensions (mm)					External dimensions drawing	Approx. weight (kg)			
			W	H	D	W1	H1					
200V	18.5	VFP7-2185P	245	390	207	225	370	A	16			
	22	VFP7-2220P							16			
	30	VFP7-2300P							23			
	37	VFP7-2370P	300	555	197	200	537		B	24		
	45	VFP7-2450P								24		
	55	VFP7-2550P								48		
	75	VFP7-2750P	370	630	290	317.5	609			C	48	
	90	VFP7-2900P									49	
	110	VFP7-2110KP									72	
400V	18.5	VFP7-4185P	245	390	207	225	370	A			16	
	22	VFP7-4220P									16	
	30	VFP7-4300P									24	
	37	VFP7-4370P	300	555	197	200	537		B		24	
	45	VFP7-4450P									24	
	55	VFP7-4550P									48	
	75	VFP7-4750P	370	630	290	317.5	609			C	48	
	90	VFP7-4900P									49	
	110	VFP7-4110KP									75	
	132	VFP7-4132KP	480	680	330	426	652				D	77
	160	VFP7-4160KP										77
	200	VFP7-4200KP										166
	220	VFP7-4220KP	660	950	370	598	920		E			166
	280	VFP7-4280KP										168
	315	VFP7-4315KP										168

Selection of wiring equipment

Selection of wiring equipment

Voltage class	Applicable motor (kW)	Inverter	Molded case circuit breaker(MCCB) Earth leakage circuit breaker (ELCB)				Magnetic contactor (MC)				Overload relay(THR)		Wire size *4 *5				Screw size of Inverter terminal		
			without reactor		without reactor		without reactor		without reactor		Regulated amperage (reference) [A]	Type form	Main circuit (mm²) *3	DC rector (optional) (mm²)	Braking resistor/braking unit (optional) (mm²)	Grounding cable (mm²) *6	Main circuit terminal	Control terminal	Grounding terminal
			Rated current (A)	MCCB type form [ELCB type form]	Rated current (A)	MCCB type form [ELCB type form]	Rated current (A)	Type form	Rated current (A)	Type form									
200V	18.5	VFP7-2185P	150	NJ225FB [NJV225FB]	125	NJ225FB [NJV225FB]	95	LC1D956	80	LC1D806	70	T100J	22	38	8.0	22	M8	M6	
	22	VFP7-2220P	175	NJ225FB [NJV225FB]	125	NJ225FB [NJV225FB]	115	LC1D1156	95	LC1D956	85	T115J	38	60	14	38	M8	M6	
	30	VFP7-2300P	225	NJ225FB [NJV225FB]	175	NJ225FB [NJV225FB]	150	LC1D1506	150	LC1D1506	110	T150J	60	100	22	60	M10	M3	
	37	VFP7-2370P	250	NJ225FB [NJV225FB]	200	NJ225FB [NJV225FB]	185	LC1F185	150	LC1D1506	138	T150J	100	150	38	100	M10	M3	
	45	VFP7-2450P	350	NJ400F [NJV400F]	250	NJ400F [NJV400F]	225	LC1F225	185	LC1F185	162	T185J	150	200	60	150	M12	M12	
	55	VFP7-2550P	400	NJ400F [NJV400F]	350	NJ400F [NJV400F]	330	LC1F330	225	LC1F225	198	LR9F53J	200	150X2	38	100	M12	M12	
	75	VFP7-2750P	-	-	400	-	-	-	330	LC1F330	252	LR9F73J	150	200	60	100	M12	M12	
	90	VFP7-2900P	-	-	500	NJ600F [NJV600F]	-	-	330	LC1F330	314	LR9F73J	200	150X2	38	100	M12	M12	
	110	VFP7-2110KP	-	-	600	NJ600F [NJV600F]	-	-	400	LC1F400	396	LR9F73J	200	150X2	38	100	M12	M12	
	400V	18.5	VFP7-4185P	75	NJ100FB [NJV100FB]	60	NJ100FB [NJV100FB]	50	LC1D506	40	LC1D406	35	LR3D356	8	14	5.5	8	M8	M6
22		VFP7-4220P	100	NJ100FB [NJV100FB]	75	NJ100FB [NJV100FB]	65	LC1D656	50	LC1D506	44	T65J	14	22	14	14	M8	M6	
30		VFP7-4300P	125	NJ225FB [NJV225FB]	100	NJ225FB [NJV225FB]	80	LC1D806	65	LC1D656	57	T100J	22	38	22	22	M8	M6	
37		VFP7-4370P	150	NJ225FB [NJV225FB]	125	NJ225FB [NJV225FB]	95	LC1D956	80	LC1D806	65	T100J	38	60	14	38	M8	M6	
45		VFP7-4450P	175	NJ225FB [NJV225FB]	125	NJ225FB [NJV225FB]	115	LC1D1156	80	LC1D806	85	T115J	38	60	14	38	M8	M6	
55		VFP7-4550P	200	NJ225FB [NJV225FB]	175	NJ225FB [NJV225FB]	150	LC1D1506	115	LC1D1156	100	T150J	60	100	38	100	M10	M10	
75		VFP7-4750P	300	NJ400F [NJV400F]	225	NJ400F [NJV400F]	185	LC1F185	150	LC1D1506	138	T150J	80	100	60	100	M10	M10	
90		VFP7-4900P	-	-	300	-	-	185	LC1F185	155	T185J	100	100	22	60	100	M10	M10	
110		VFP7-4110KP	-	-	350	NJ400F [NJV400F]	-	-	225	LC1F225	198	LR9F53J	150	150	60	100	M12	M12	
132		VFP7-4132KP	-	-	400	NJ400F [NJV400F]	-	-	265	LC1F265	252	LR9F53J	200	100X2	60	100	M12	M12	
160		VFP7-4160KP	-	-	400	NJ400F [NJV400F]	-	-	330	LC1F330	268	LR9F53J	200	150X2	60	100	M12	M12	
200		VFP7-4200KP	-	-	500	NJ600F [NJV600F]	-	-	400	LC1F400	384	LR9F73J	200	100X2	60	100	M12	M12	
220		VFP7-4220KP	-	-	600	NJ600F [NJV600F]	-	-	400	LC1F400	396	LR9F73J	200	150X2	60	100	M12	M12	
280		VFP7-4280KP	-	-	700	NJ800F [NJV800F]	-	-	500	LC1F500	460	LR9F73J	150X2	200X2	100	150	M12	M12	
315		VFP7-4315KP	-	-	800	NJ800F [NJV800F]	-	-	630	LC1F630	504	LR9F73J	150X2	200X2	100	150	M12	M12	

Notes)

*1: Attach a surge killer to the exciting coil of every magnetic contactor and relay. Selection of surge killers for Toshiba magnetic contactors

200V class: Type SS-2 (optional surge absorbing units are available for C11J to C65J.)

400V class: The voltages of the operation and control circuits should be reduced below 200V with a step-down transformer.

*2: When using a magnetic contactor MC with auxiliary 2a contacts for the control circuit, connect the 2a contacts in parallel to improve their reliability.

*3: Size of the wires connected to the input terminals R, S and T and the output terminals U, V and W when the length of each wire does not exceed 30m.

*4: The above table provides a listing of , wires of the type HIV 600V.

*5: For the control circuit, use shielded wires 0.75 mm² or more in diameter.

*6: For grounding, use a cable with a size equal to or larger than the above.

Standard connection.

Description of terminal functions

Standard connection diagram for 22kW and smaller models

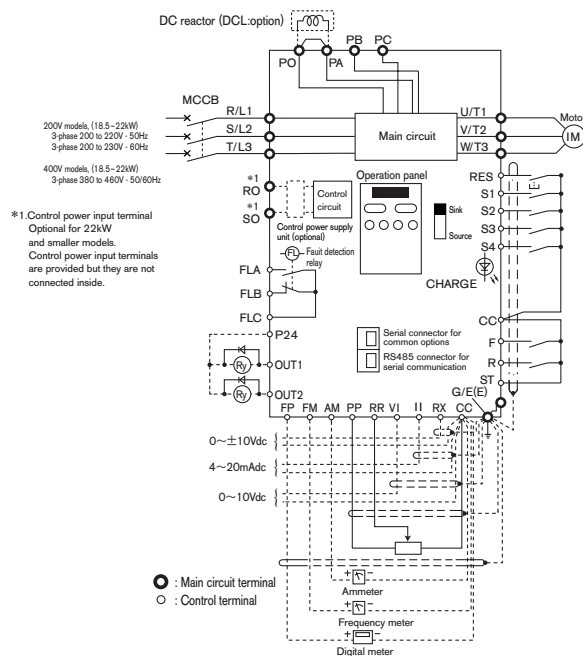

Standard connection diagram for 30 (30) kW to 110 (315) kW models () Capacity for 400V models

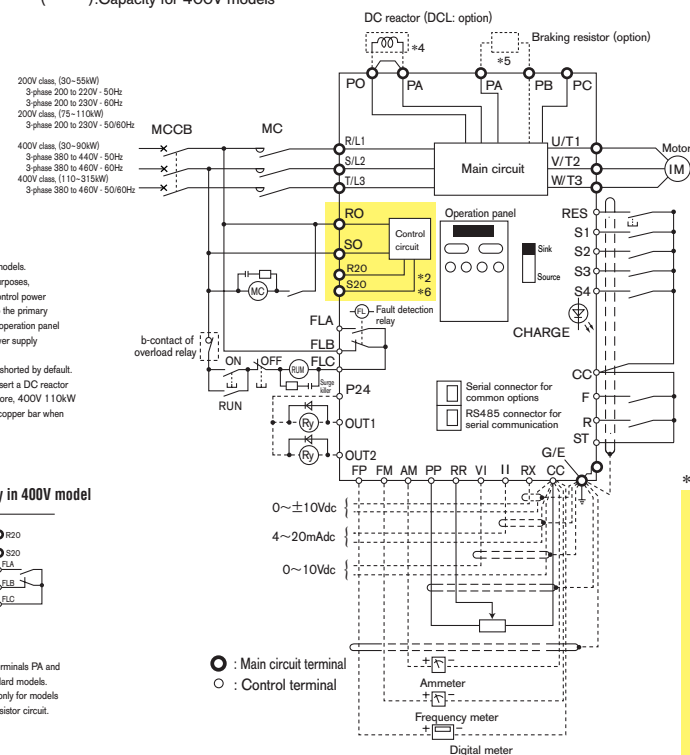

#2: Only for 400V 90kW and larger models.

#3: For maintenance and inspection purposes,

the RO and SO terminals of the control power supply unit should be connected to the primary side of the main circuit so that the operation panel can be checked only when the power supply unit is on.

#4: The circuit between PO and PA is shorted by default. Before use, however, be sure to insert a DC reactor (DCL) for the 200V 75kW and more, 400V 110kW and more. Be sure to remove the copper bar when a DCL is used.

Connection of a run relay in 400V model

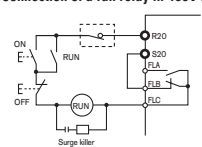

#5: The braking resistor connection terminals PA and PB are not provided for the standard models. These connectors are necessary only for models with an optional built-in braking resistor circuit.

#6: 400V 45kW and larger models

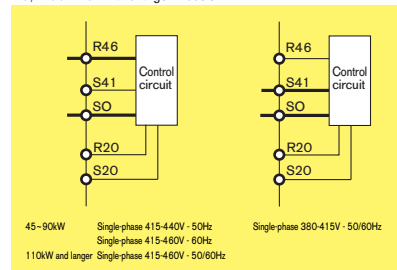

Main circuit terminals

Terminal symbol	Terminal function
G/E	Inverter grounding terminal
R/L1, S/L2, T/L3	200V class: 3-phase 200 to 220V-50Hz, 200 to 230V-60Hz for 55kW and smaller models 3-phase 200 to 230V-50/60Hz for 75kW and larger models 400V class: 3-phase 380 to 460V-50/60Hz for 22kW and smaller models 3-phase 380 to 440V-50Hz, 380 to 460V-60Hz for 30 to 90kW models 3-phase 380 to 460V-50/60Hz for 110kW and larger models
U/T1, V/T2, W/T3	Connect to a motor (three-phase induction motor).
PA, PB	Connect to the braking resistor (optional). Set the braking resistor operation parameters.
PC	Minus potential terminal for internal DC main circuit (Note: Contact us for more information when using this for the 200V/400V 18.5 and 22kW models) DC common power can be supplied with this terminal and the PA terminal (plus potential).
PO, PA	Terminals for connecting a DC reactor (DCL: optional external unit). Every inverter is shipped with these terminals short-circuited with a copper bar. Be sure to remove the bar connecting the PO and the PA, when a DC reactor is used. Be sure to install a DC reactor (DCL) for the 200V 75kW and larger models or 400V 110kW and larger models.
RO, SO (R46, R41)	Control power input terminals [200V class] 30 to 55kW: Connect to a single-phase 200 to 220V-50Hz or 200 to 230V-60Hz. 75kW and larger: Connect to a single-phase 200 to 230V-50/60Hz. [400V class] 30 to 90kW: Connect to a single-phase 380 to 440V-50Hz or 380 to 460V-60Hz. 110kW and larger: Connect to a single-phase 380 to 460V-50/60Hz. R46 and SO: Connect to a single-phase 415 to 460V-50/60Hz. R41 and S0: Connect to a single-phase 380 to 415V-50/60Hz. Optional for 18.5 to 22kW models
R20, S20	Power supply output terminals for operation circuit, installed in the 400V class 45kW and larger models. (10VA) 45 to 90kW: Single-phase 207.5 to 220V-50Hz Single-phase 207.5 to 230 V-60Hz 110kW and larger: Single-phase 207.5 to 230V-50/60Hz

Control circuit terminals

The functions of each terminal can be changed according to its application.

Terminal symbol	Terminal function
FLA, FLB, FLC	Multifunction programmable relay output contacts. Contact ratings: 250Vdc -2A (cosφ=1), 30Vdc-1A, 250Vac-1A (cosφ=0.4) By default, these are set to the function of detecting the activation of the inverter's protective circuit. If the protective circuit is activated, the FLA and FLC circuit is closed, while the FLB and FLC circuit is opened.
P24	24Vdc power output (Max. 100mA)
OUT1	Multifunction programmable open-collector output (Max. 50mA) By default, these are set to the function of detecting a low speed and sending out a signal. Sink/source switchable.
OUT2	Multifunction programmable open-collector output (Max. 50mA) By default, these are set to the function of detecting the attainment of a command frequency and sending out a signal. Sink/source switchable.
FP	Multifunction programmable open-collector output (Max. 50mA) This produces pulses of 1.00 to 43.2kHz according to the parameter setting. Default setting is 3.84kHz.
FM	Multifunction programmable analog signal output. This terminal sends out signals converted from the actual values. By default, it is set to frequency before compensated. When connecting a meter, use a 1mA full-scale ammeter or a 7.5Vdc-1mA full-scale voltmeter.
AM	Multifunction programmable analog signal output. This terminal sends out signals converted from the actual values. By default, it is set to output voltage. When connecting a meter, use a 1mA full-scale ammeter or a 7.5Vdc-1mA full-scale voltmeter.
PP	Power output terminal for reference frequency setting (10Vdc). Connect a 3kΩ potentiometer. (Connectable potentiometer: 1 to 10kΩ-rated potentiometers).
RR	Multifunction programmable analog signal input. By default, this terminal is set to frequencies of 0 to 80Hz at 0 to 10Vdc.
VI	Multifunction programmable analog signal input. By default, this terminal is set to frequencies of 0 to 80Hz at 2 to 10Vdc.
II	Multifunction programmable analog signal input. Default setting: frequencies of 0 to 80Hz at 4 to 20mA
RX	Multifunction programmable +/- analog signal input, switchable between 0 to ±, 10Vdc and 0 to ±5Vdc. Default setting: 0 to 80Hz at 0 to 10Vdc for forward/reverse switching.
CC	Common terminal for control circuit.
ST	Default setting: ready for start if ST and CC are short-circuited and stop of free-run if the circuit is opened. This terminal can be used for interlock. (Ready for start/coasting terminal)
F	Default setting: forward run if F and CC is short-circuited and slowdown stop if this circuit is opened. (ST and CC are short-circuited.)
R	Default setting: reverse run if R and CC are short-circuited and slowdown stop if this circuit is opened. (ST and CC are short-circuited.) If F-CC circuit and R-CC circuit are shorted simultaneously, then reverse run is selected. (This setting can be changed.)
S1	Default setting: Preset-speed operation if S1 and CC are short-circuited
S2	Default setting: Preset-speed operation if S2 and CC are short-circuited
S3	Default setting: Preset-speed operation if S3 and CC are short-circuited
S4	Default setting: Preset-speed operation if S4 and CC are short-circuited
RES	Default setting: Holding of the status conditions when the inverter's protective function was triggered, is reset if RES and CC are short-circuited.

Basic and extended parameters

Basic parameters

Basic parameters refer to parameters which need to be set before the first use after purchasing the inverter. Among these parameters are the parameters of acceleration/deceleration times, preset-speed operation, motor control selection.

Title	Function	Adjustment range	Default setting	
RU1	Automatic acceleration/deceleration	0: Manual acceleration/deceleration 1: Automatic acceleration/deceleration	0	
RU2	Automatic V/f mode setting	0: - 1: Automatic torque boost + auto-tuning 2: Sensorless vector control (speed) + auto-tuning 3: Automatic energy-saving + auto-tuning	0	
CROd	Operation command mode selection	0: Terminal block enabled 1: Operation panel enabled 2: Common serial communication option 3: Serial communication RS485 4: Communication add-on option enabled	0	
FROd	Speed setting mode selection	1: VI (voltage input)/II (current input) 2: RR (Potentiometer/voltage input) 3: RX (voltage input) 4: RX2 (voltage input) (optional) 5: Operation panel input enabled 6: Binary/BCD input 7: Common serial communication option 8: Serial communication RS485 9: Communication add-on module option 10: Up-down frequency 11: Pulse input 1 (optional for sensor vector control)	2	
FNSL	Selection of meter connected to FM terminal	0 to 32	0	
FN	Calibration of meter connected to FM terminal	—	—	
LYP	Standard setting mode selection	0: - 1: 50Hz standard setting 2: 60Hz standard setting 3: Factory default setting 4: Trip clear 5: Clearing accumulating operation time 6: Initialization of type form 7: Memorization of user-defined parameters 8: Reset of user-defined parameters	0	
FR	Forward/reverse selection (At panel control only)	0: Forward, 1: Reverse	0	
ACC	Acceleration time #1	0.1(F50B)~6000[sec]	Model dependent	
DEC	Deceleration time #1	0.1(F50B)~6000[sec]	Model dependent	
FH	Maximum frequency	30.0~400[Hz]	80.0	
UL	Upper limit frequency	0.0~FH[Hz]	80.0	
LL	Lower limit frequency	0.0~UL[Hz]	0.0	
UL	Base frequency #1	25~400 [Hz]	60	
PE	Motor control mode selection	0: Constant torque 1: Variable torque mode 2: Automatic torque boost 3: Sensorless vector control (speed) 4: Automatic torque boost + automatic energy-saving 5: Sensorless vector control (speed) + automatic energy-saving 6: V/f 5-points setting 7: Sensorless vector control (speed/torque switching) 8: PG feedback vector control (speed/torque switching) 9: PG feedback vector control (speed/position switching)	0	
LB	Manual torque boost #1	0~30 [%]	Model dependent	
OLN	Selection of electronic thermal protection characteristics	Setting		
		Standard motor	Overload protection	valid
			Overload stall	invalid
			Overload protection	valid
			Overload stall	invalid
		VF motor (special motor for inverters)	Overload protection	valid
			Overload stall	invalid
			Overload protection	valid
Overload stall	invalid			
SR1	Preset-speed #1	LL~UL [Hz]	0.0	
SR2	Preset-speed #2	LL~UL [Hz]	0.0	
SR3	Preset-speed #3	LL~UL [Hz]	0.0	
SR4	Preset-speed #4	LL~UL [Hz]	0.0	
SR5	Preset-speed #5	LL~UL [Hz]	0.0	
SR6	Preset-speed #6	LL~UL [Hz]	0.0	
SR7	Preset-speed #7	LL~UL [Hz]	0.0	
FI	Extended parameter	Setting of extended parameters listed on the following pages	—	
FS				
GR.U	Automatic edit function	Displays parameters differ from the standard setting values.	—	

Extended parameters

Extended parameters are used for detailed setting.

Title	Function	Adjustment range	Default setting
F100	Low-speed signal output frequency	0.0~UL [Hz]	0.0
F101	Speed reach setting frequency	0.0~UL [Hz]	0.0
F102	Speed reach detection band	0.0~UL [Hz]	2.5
F103	ST (standby) signal selection	0: standard, 1: Always ON, 2: Linked with F/R terminals	0
F105	Priority selection (both F-CC, R-CC is ON)	1: Reverse, 1: Stop	0
F106	Priority setting of input terminal	0: Disabled, 1: Enabled	0
F107	Binary/BCD signal selection (Extended terminal add-on cassette option)	0: None 1: 12-bit binary code 2: 16-bit binary code 3: 3-digit BCD code 4: 4-digit BCD code 5: Reverse 12-bit binary input 6: Reverse 16-bit binary input 7: Reverse 3-digit BCD input 8: Reverse 4-digit BCD input	0
F108	Up-down frequency	0~7	0
F110	Always active function selection	0~135	0
F111	Input terminal selection #1 (F)	0~135	2(F)
F112	Input terminal selection #2 (R)	0~135	4(R)
F113	Input terminal selection #3 (ST)	0~135	6(ST)
F114	Input terminal selection #4 (RES)	0~135	8(RES)
F115	Input terminal selection #5 (S1)	0~135	10(S1)
F116	Input terminal selection #6 (S2)	0~135	12(S2)
F117	Input terminal selection #7 (S3)	0~135	14(S3)
F118	Input terminal selection #8 (S4)	0~135	16(S4)
F130	Output terminal selection #1 (OUT1)	0~119	4(LOW)
F131	Output terminal selection #2 (OUT2)	0~119	6(RCH)
F132	Output terminal selection #3 (FL)	0~119	10(FL)
F170	Base frequency 2	25~400 [Hz]	60
F171	Base frequency voltage 2	0~600[V]	Model dependent
F172	Manual torque boost 2	0~30[%]	Model dependent
F173	Motor overload protection level 2	10~100[%]	100
F174	Base frequency 3	25~400 [Hz]	60
F175	Base frequency voltage 3	0~600[V]	Model dependent
F176	Manual torque boost 3	0~30[%]	Model dependent
F177	Motor overload protection level 3	10~100[%]	100
F178	Base frequency 4	25~400 [Hz]	60
F179	Base frequency voltage 4	0~600[V]	Model dependent
F180	Manual torque boost 4	0~30[%]	Model dependent
F181	Motor overload protection level 4	10~100[%]	100
F182	Motor switching mode selection	0: Standard, 1: Customized	0
F183	V/f adjustment coefficient	0~255	32
F200	Speed command priority selection	0: FROd, 1: F207, 2: FROd priority 3: F207 priority, 4: FROd/F207 switching	0
F201	VI/II reference point #1	0~100[%]	20.0
F202	VI/II reference point #1 frequency	0~FH [Hz]	0.0
F203	VI/II reference point #2	0~100[%]	100
F204	VI/II reference point #2 frequency	0~FH [Hz]	80.0
F205	VI/II reference point #1 %	0~250[%] (For torque control)	0
F206	VI/II reference point #2 %	0~250[%] (For torque control)	100
F207	Speed setting mode selection #2	Same as FROd (1 to 11)	1
F208	FROd/F207 switching frequency	0.1~FH [Hz]	1.0
F209	Analog input filter	0 (disabled) to 3 (max. filter capacity)	0
F210	RR reference point #1	0~100[%]	0
F211	RR point #1 frequency	0~FH [Hz]	0.0
F212	RR reference point #2	0~100[%]	100
F213	RR point #2 frequency	0~FH [Hz]	80.0
F214	RR point #1 %	0~250[%] (For torque control)	0
F215	RR point #2 %	0~250[%] (For torque control)	100
F216	RX reference point #1	-100~100[%]	0
F217	RX point #1 frequency	-FH~FH [Hz]	0.0
F218	RX reference point #2	-100~100[%]	100
F219	RX point #2 frequency	-FH~FH [Hz]	80.0
F220	RX reference point #1 %	-250~250[%] (For torque control)	0
F221	RX reference point #2 %	-250~250[%] (For torque control)	100
F224	Start-up frequency setting	0.0~10 [Hz]	0.1
F241	Run frequency setting	0.0~FH[Hz]	0.0
F242	Run frequency hysteresis	0.0~30 [Hz]	0.0
F243	End frequency setting	0.0~30 [Hz]	0.0
F270	Jump frequency #1	0.0~FH[Hz]	0.0
F271	Jump frequency band #1	0.0~30 [Hz]	0.0
F272	Jump frequency #2	0.0~FH[Hz]	0.0
F273	Jump frequency band #2	0.0~30 [Hz]	0.0
F274	Jump frequency #3	0.0~FH[Hz]	0.0
F275	Jump frequency band #3	0.0~30 [Hz]	0.0
F276	Processing item selection	0: Processing amount, 1: Output frequency	0
F287	Preset-speed frequency #8	LL~UL [Hz]	0.0
F288	Preset-speed frequency #9	LL~UL [Hz]	0.0
F289	Preset-speed frequency #10	LL~UL [Hz]	0.0
F290	Preset-speed frequency #11	LL~UL [Hz]	0.0
F291	Preset-speed frequency #12	LL~UL [Hz]	0.0
F292	Preset-speed frequency #13	LL~UL [Hz]	0.0
F293	Preset-speed frequency #14	LL~UL [Hz]	0.0
F294	Preset-speed frequency #15	LL~UL [Hz]	0.0
F300	PWM carrier frequency	0.5~15.0[kHz]*1	Model dependent
F301	Auto-restart (motor speed search)	0: Disabled, 1: Available at power failure, 2: ST ON/OFF, 3: 1+2	0
F302	Regenerative power ride-through control/Deceleration stop	0: OFF, 1: ON, 2: ON(Deceleration stop)	0
F303	Retry selection	0: Disabled, 1 to 10 times	0
F304	Dynamic braking mode selection	0: Disabled, 1: Enabled/overload detection enabled	Model dependent

Title	Function	Adjustment range	Default setting
F305	Over voltage stall protection	0: Disabled, 1: Enabled, 2: Enabled (Forced shorted deceleration)	0
F306	Voltage of base frequency (output voltage adjustment)	0~600[V]	Model dependent
F307	Selection of base frequency voltage (Voltage correction)	0: without voltage correction (output voltage not limited) 1: with voltage correction (output voltage not limited) 2: without voltage correction (output voltage limited) 3: with voltage correction (output voltage limited)	1
F308	PBR resistance	1.0~1000[Ω]	Model dependent
F309	PBR resistor capacity	0.01~600[kW]	Model dependent
F310	Ride-through time/Deceleration time	0.0~320 [sec.]	2.0
F311	Reverse-run prohibition selection	0: All directions permitted 1: Reverse run prohibited 2: Forward run prohibited 3: Direction designated by command permitted	0
F312	Auto-restart adjustment parameter 1	0.5~250	Model dependent
F313	Auto-restart adjustment parameter 2	0.5~250	Model dependent
F314	Auto-restart method selection	0~4	Model dependent
F315	Auto-restart adjustment parameter 3	0~9	1
F354	Output signal selection of commercial power/inverter switching	0: OFF 1: Automatic switching in case of trip 2: Commercial power switching frequency setting enabled 3: Commercial power switching frequency setting enabled Automatic switching in case of trip	0
F355	Commercial power/inverter switching frequency	0.0~FH [Hz]	60.0
F356	Inverter-side switching waiting time	Model dependent~10.0 [sec.]	Model dependent
F357	Commercial power-side switching waiting time	0.1~10.0 [sec.]	0.62
F358	Commercial power switching frequency holding time	0.1~10.0 [sec.]	2.0
F360	Signal selection of PID control	0: PID control disabled, 1: VIII, 2: RR, 3: RX, 4: RX2	0
F361	Delay filter	0~255	0
F362	Proportional (P) gain	0.01~100	0.1
F363	Integral (I) gain	0.01~100	0.1
F364	PID deviation upper limit	0~50[%]	50
F365	PID deviation lower limit	0~50[%]	50
F366	Differential (D) gain	0.0~2.55	0
F400	Auto-tuning selection	0: Without auto-tuning (internal table) 1: Motor constant initialization 2: Auto-tuning execution (0 after executed)	0
F401	Slip frequency gain	0.0~2.55	0.60
F402	Motor constant 1 (primary resistance)	0.0~10000[mΩ]	Model dependent
F403	Motor constant 2 (secondary resistance)	0.0~10000[mΩ]	Model dependent
F404	Motor constant 3 (exciting inductance)	0.0~6500[mH]	Model dependent
F405	Motor constant 4 (load inertia moment)	0.0~100.0	1.0
F410	Motor constant 5 (leak inductance)	0.0~650.0[mH]	Model dependent
F411	Number of poles of motor	2, 4, 6, 8, 10, 12, 14, 16[pole]	4
F412	Rated capacity of motor	0.1~Model dependent[kW]	Model dependent
F413	Motor type	0: Standard motor #1 1: VF motor 2: V3 motor 3: Standard motor #2 4: Other motors	0
F414	Prohibition of auto-tuning	0: Prohibited, 1: Auto-tuning if F400=2	1
F440	Selection of power running torque limit #1	0: Disabled, 1: VIII, 2: RR, 3: RX, 4: RX2, 5: F441	5
F441	Power running torque limit #1	0~249.9 [%], 250: Disabled	250.0
F442	Selection of regenerative torque limit #1	0: Disabled, 1: VIII, 2: RR, 3: RX, 4: RX2, 5: F443	5
F443	Regenerative torque limit #1	0~249.9[%], 250: Disabled	250.0
F444	Power running torque limit #2	0~249.9[%], 250: Disabled	250.0
F445	Regenerative torque limit #2	0~249.9[%], 250: Disabled	250.0
F446	Power running torque limit #3	0~249.9[%], 250: Disabled	250.0
F447	Regenerative torque limit #3	0~249.9[%], 250: Disabled	250.0
F448	Power running torque limit #4	0~249.9[%], 250: Disabled	250.0
F449	Regenerative torque limit #4	0~249.9[%], 250: Disabled	250.0
F450	Torque limit mode selection	0: Power-running/regenerative torque limit, 1: Positive/negative torque limit	0
F451	Torque limit mode	0: Standard, 1: no speed cooperation	0
F500	Acceleration time #2	F50B~6000[sec.]	Model dependent
F501	Deceleration time #2	F50B~6000[sec.]	Model dependent
F502	Acceleration/deceleration #1 pattern	0: Linear, 1: S-pattern 1, 2: S-pattern 2	0
F503	Acceleration/deceleration #2 pattern	0: Linear, 1: S-pattern 1, 2: S-pattern 2	0
F504	Panel acceleration/deceleration #1, 2, 3, 4 selection	1: Acceleration/deceleration #1 2: Acceleration/deceleration #2 3: Acceleration/deceleration #3 4: Acceleration/deceleration #4	1
F505	ACC/Dec switching frequency #1	0.0~FH [Hz]	0
F506	S-pattern lower-limit adjustment amount	0~50[%]	25
F507	S-pattern upper-limit adjustment amount	0~50[%]	25
F508	ACC/Dec time lower limit	0.01~10[sec.]	0.1
F510	Acceleration time #3	F50B~6000[sec.]	Model dependent
F511	Deceleration time #3	F50B~6000[sec.]	Model dependent
F512	ACC/Dec #3 pattern	0: Linear, 1: S-pattern 1, 2: S-pattern 2	0
F513	ACC/Dec switching frequency #2	0.0~FH [Hz]	0.0
F514	Acceleration time #4	F50B~6000[sec.]	Model dependent
F515	Deceleration time #4	F50B~6000[sec.]	Model dependent
F516	ACC/Dec #4 pattern	0: Linear, 1: S-pattern 1, 2: S-pattern 2	0
F517	ACC/Dec switching frequency #3	0.0~FH [Hz]	0.0
F600	Motor overload protection level 1	10~100 [%]	100
F601	Stall prevention level 1	0~199[%], 200: Disabled	120
F602	Selection of inverter trip holding	0: Cleared if power is turned off 1: Held even if power is turned off	0
F603	Emergency stop mode selection	0: Coast stop 1: Deceleration stop 2: Emergency DC injection braking stop 3: Coast stop without FL output 4: Deceleration stop without FL output 5: Emergency DC injection braking without FL output	0

*A selection can be made between "parameter trip enabled" and "parameter trip disabled".

Extended parameters

	Title	Function	Adjustment range	Default setting	
Protective functions	F604	Emergency DC injection braking stop control time	0.0~10.0[sec.]	0.1	
	F605	Output phase failure detection parameter	0: Not selected, 1: Selected	0	
	F606	OL reduction starting frequency	0~30[Hz]	6.0	
	F607	Motor 150% overload time limit	10~2400[sec.]	600	
	F608	Timing of relay for suppressing rushed current	0.3~2.5[sec.]	0.3	
	F609	Mode selection of relay for suppressing rushed current	0: Standard, 1: Gearing of ST	0	
	F610	Low current trip mode selection	0: Not selected 1: Selected	0	
	F611	Low current (trip/alarm) detection current	0~100 [%]	0	
	F612	Low current (trip/alarm) detection time	0~255[sec.]	0	
	F613	Selection of output short-circuit pulse during start-up	0: Default setting, 1: Only one time when power is turned on or at first start after reset	0	
	F614	Adjustment of output short-circuit pulse during start-up	1 to 100 [msec.]	50	
	F615	Over-torque trip selection	0: Trip disabled 1: Trip enabled	0	
	F616	Over-torque (trip/alarm) level during power operation	0~250 [%]	120	
	F617	Over-torque (trip/alarm) level during regeneration	0~250 [%]	120	
	F618	Over-torque detection time	0.0~10.0 [sec.]	0.5	
	F620	Cooling fan control mode selection	0: Automatic, 1: Always ON	0	
	F621	Cumulative run timer alarm setting	0.1~999.9	175.0	
	F622	Abnormal speed detection filter	0.01~100 [sec.]	10.00	
	F623	Over-speed detection frequency range	0: Disabled, 0.1~30.0[Hz]	0	
	F624	Speed drop detection frequency range	0: Disabled, 0.1~30.0[Hz]	0	
	F625	Overvoltage limit operation level (high response)	100~250 [%]	135	
	F626	Overvoltage limit operation level	100~250 [%]	130	
	F627	Undervoltage trip mode selection	0: Trip disabled 1: Trip	0	
	F628	Undervoltage (trip/alarm) detection time	0~10 [sec.]	0.03	
	F629	UV stall level	50~100 [%]	75	
	F630	System sequence	0.0: Disabled, 0.01~10 [sec.]	0.0	
	F631	Position deviation limit	0.1~6553	16.0	
	F632	Break release prohibition time after operation	0.00~2.50, 0.00: F612 effective	0.00	
	F633	VIA low level trip selection	0-100	0	
	Meter output	F670	AM terminal meter selection	0~32	2 output current
		F671	AM-terminal meter adjustment	—	—
		F700	Selection of prohibition of parameter setting	0: Allowed, 1: Prohibited	0
		F701	Selection of current/voltage display mode	0: %; 1: A (ampere)/V (volt)	0
F702		Frequency free unit magnification	0:OFF, 0.01~200	0	
F703		Selection of decimal place number of frequency	0:1Hz, 1:0.1Hz, 2:0.01Hz	1	
F704		Setting of acceleration/deceleration time unit	0: 1 sec., 1: 0.1 sec., 2: 0.01 sec.	1	
F709		Permission/prohibition of changes to user parameters at the initialization of formal information (L3P=6)	0: Permitted, 1: Prohibited	0	
F710		Selection of monitor display mode	0~29	0	
F711		Selection of status monitor #1 display mode	0~29	1	

	Title	Function	Adjustment range	Default setting
Control panel parameters	F712	Selection of status monitor #2 display mode	0~29	2
	F713	Selection of status monitor #3 display mode	0~29	3
	F714	Selection of status monitor#4 display mode	0~29	4
	F720	Selection of panel V/F 1, 2, 3 or 4	1, 2, 3, 4	1
	F721	Selection of panel stop pattern	0: Deceleration stop, 1: Free run	0
	F722	Panel reset function selection	0: Disabled, 1: Enabled	1
	F723	Panel torque limit selection	1, 2, 3, 4	1
	F724	Panel PID control OFF	0: ON 1: OFF	0
	F725	Panel torque command	0~250[%]	0
	F726	Panel external torque revise	~250~250[%]	0
F727	Panel tension torque reference	~250~250[%]	0	
F728	Panel load sharing gain	0~250[%]	100	
F729	Panel override multiplication gain	~100~100[%]	0	
Communication function	F730	Panel operation inhibit	0: All key operations disabled +1: Panel frequency setting enabled +2: Parameter editing enabled +4: Monitor display operation enabled +8: Panel operation enabled +32: Emergency stop operation enabled 63: Default mode (all key operation enabled)	63
	F800	Communication baud rate (common serial)	0:1200, 1:2400, 2:4800, 3:9600	3
	F801	Parity (for both common serial and RS485)	0: Non parity, 1: Even parity, 2: Odd parity	1
	F802	Inverter number(common)	0~255	0
	F803	Communication time-out (for both common serial and RS485)	0: Off, 1~100 [sec.]	0
	F804	Communication time-out activation (for both common serial and RS485)	0~8	8
	F805	Transmission waiting time (for both common serial and RS485)	0.00: Default, 0.01 to 2.00	0.00
	F806	Inverter-to-inverter communication setting (for common serial)	0: Default, 1: Frequency command, 2: Output frequency 3: Torque command, 4: Output torque command	0
	F810	Frequency point selection	0: Disabled, 1: Common serial, 2: RS485, 3: Communication add-on option	0
	F811	Point #1 setting	0~100[%]	0
F812	Point #1 frequency	0~FH[Hz]	0	
F813	Point #2 setting	0~100[%]	100	
F814	Point #2 frequency	0~FH[Hz]	80	
F820	Communication baud rate (RS485)	0:1200, 1:2400, 2:4800, 3:9600, 4:19200, 5:38400	3	
F821	RS-485 connection system	0: 2-line system, 1: 4-line system	1	
F825	RS-485 transmission waiting time	0: Normal, 0.01~2	0	
F826	Inter-drive communication setup (RS-485)	0: Default, 1: Frequency command, 2: Output frequency 3: Torque command, 4: Output torque command	0	

Special parameters

Title	Function
F119~F126	Selection of input terminal function (for extended terminal board)
F133~F136	Selection of output terminal function (for extended terminal board)
F140~F166	I/O terminal response time setting
F190~F199	V/f 5-point setting
F222~F237	Setting of speed torque command gain and bias (for extended terminal board)
F244	Frequency setting signal OHZ dead zone frequency
F250~F255	DC braking
F260~F261	Jogging
F320~F327	Drooping control
F330~F341	Function designed for elevators
F367~F373	Speed feedback/positioning control
F374~F379	Vector control
F380~F395	Preset-speed operation mode

Title	Function
F396~F398	Torque control
F420~F433	Torque control
F452	Continuous trip detection time for a stall during power running
F453	Selection of regenerative-braking stall preventive action
F454	Current differential gain
F470~F477	Input bias and gain
F480~F491	Parameter for special adjustments
F520~F599	Pattern operation
F650~F654	Special analog input
F660~F661	Override
F672~F680	Optional meter output
F740~F772	Function of programmable controller (planned)
F830~F899	Communication function

For maintenance purposes, the following parameters are designed so that they cannot be returned to the factory default values even if **L3P=3** is selected. Also note that, of the parameters listed below, those marked X are designed so that they will not be displayed in user parameter group **G-U** when they are set to any values different from the factory default values.

Title	Function	G-U display
F75L	Selection of meter connected to FM terminal	
F77	Calibration of meter connected to FM terminal	×
F670	Selection of meter connected to AM terminal	
F671	Calibration of meter connected to AM terminal	×
F672	Selection of meter connected to optional analog terminal 1	
F673	Calibration of meter connected to optional analog terminal 1	×
F674	Selection of meter connected to optional analog terminal 2	
F675	Calibration of meter connected to optional analog terminal 2	×

Title	Function	G-U display
F470	V/II input bias	×
F471	V/II input gain	×
F472	RR input bias	×
F473	RR input gain	×
F474	RX input bias	×
F475	RX input gain	×
F476	RX2 input bias	×
F477	RX2 input gain	×

Protections

Trip display
Alarm display

List of trips

When a trip occurs, the panel LED immediately displays trip information. The cause of the trip is retained in memory even when the power is turned off.

Messages	Problems
OC 1/OC 1P	Overcurrent during acceleration (DC section)
OC 2/OC 2P	Overcurrent during deceleration (DC section)
OC 3/OC 3P	Overcurrent during constant speed run (DC section)
OC L	Overcurrent (load-side overcurrent during start-up)
OC R 1	U-phase armature short circuit
OC R 2	V-phase armature short circuit
OC R 3	W-phase armature short circuit
EPH 1	Input phase failure
*EPH 0	Output phase failure
OP 1	Overvoltage during acceleration
OP 2	Overvoltage during deceleration
OP 3	Overvoltage during constant speed run
OL 1/OL 2	Inverter overload trip motor overload trip
OL r	Dynamic braking resistor overload trip
OH	Overheat
E	Emergency stop
EEP 1	EEPROM error
EEP 2	Initial read error
EEP 3	Initial read error
Err 2	Main unit RAM fault
Err 3	Main unit ROM fault
Err 4	CPU fault
Err 5	Communication interruption error
Err 6	Gate array fault
Err 7	Output current detector error
Err 8	Optional unit fault
Err 9	Flash memory fault
*UC	Trip during low-current run
*UP 1	Undervoltage trip (main circuit)
*UP 2	Undervoltage trip (control circuit)
*OE	Overtorque trip
EF 1/EF 2	Grounding fault trip
Et r	Auto-tuning error
Et YP	Inverter type error
E-10	Sink/source switching error
E-11	Sequence error
E-12	Encoder error
E-13	Speed error
E-14	Excessive positional deviation
E-17	Key fault
E-18	V/II input error

* A selection can be made between "parameter trip enabled" and "parameter trip disabled."

Resetting the inverter

If the inverter trips because of a fault or abnormal use, do not reset the inverter before removing the cause of the trip. Note that the inverter trips again if the cause of the trip has not yet been removed.

A tripped inverter can be reset by any of the following operations:

- Turn off the power (Make sure that the LED indicator goes out.)
If the inverter cannot be reset, check the inverter trip holding setting.
- External signal (control terminal board RES-CC circuit short-circuited [Default setting]> opened)
- Panel operation

To reset the inverter from the operation panel, follow the steps below.

- Press the [STOP] key and make sure that **CL r** is displayed.
- After removing the cause of tripping, press the [STOP] key again to reset the inverter.

Alarm display

Messages	Problems
OFF	ST terminal opened
POFF	Control circuit under voltage
POFF	Main circuit under voltage
rErY	Display during retry
P-Er	Frequency point setting error alarm
CLr	Clear acceptance display
EOFF	Emergency stop acceptance display
H 1/L 0	Setting error alarm (The error detected and data are alternately displayed twice each.)
db	DC braking in process
dbon	DC braking in process
E 1	Digits over flow
EE	Communication error
E	Communication error
in 1k	During initialization of parameters
Et r	Auto-tuning

Note) When the ON/OFF function is selected from the input terminal menu for DC braking (DB), if breaking the circuit formed by the terminal selected and the CC terminal causes the message **db** to disappear, then the inverter is in a normal condition.

[Prelarm display]

Messages	Problems
C	Overcurrent
P	Overvoltage
L	Overload
H	Overheat

If more than one problem arises at a time, the following alarm messages blink: **CP, PL, LH, CPL, ...CPLH**. The message **C, P, L** and **H** are displayed in this order from the left.

Caution

The inverter can be restarted immediately by turning the power switch on after turning off temporarily. Note, however, that repeating this operation frequently may damage the inverter and the motor.

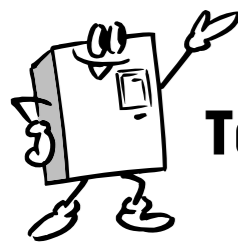

To users of our inverters

When wiring the inverter

Wiring precautions

Installing a molded-case breaker [MCCB]

- (1) Install a molded-case circuit breaker (MCCB) on the inverter's power supply input to protect the wiring.
- (2) Avoid turning the MCCB on and off frequently to turn on/off the motor.
- (3) To turn on/off the motor frequently, close/break the control terminals F (or R)-CC.

Installing a magnetic contactor [MC] [primary side]

- (1) To prevent an automatic restart after the power interruption or overload relay has tripped, or actuation of the protective circuit, install an electro-magnetic contact in the power supply.
- (2) Because the VF-P7 inverter has a built-in fault detection relay [FL], the primary end magnetic contactor (MC) can be configured to trip on activation of the inverter's protective functions by connecting the contact points of the FL to the operation circuit of the MC.
- (3) The inverter can be used without a magnetic contactor. In this case, use an MCCB (equipped with a voltage tripping device) for opening the primary circuit when the inverter protective circuit is activated.
- (4) Avoid turning the magnetic contactor on and off frequently to turn on/off the motor.
- (5) To turn on/off the motor frequently, close/break the control terminals F (or R)-CC.
- (6) Install a surge suppressor on the excitation coil of the magnetic contactor (MC).

Installing a magnetic contactor [MC] [secondary side]

- (1) As a rule, if a magnetic contactor is installed between the inverter and the motor, do not turn ON/OFF while running. (If the secondary-side contactor is turned ON/OFF while running, a large current may flow in the inverter, causing inverter damage and failure.)
- (2) A magnetic contactor may be installed to change the motor or change to the commercial power source when the inverter is stopped. Always use an interlock with the magnetic contactor in this situation so that the commercial power supply is not applied to the inverter's output terminals.

External signal

- (1) Use a relay rated for low currents. Mount a surge suppressor on the excitation coil of the relay.
- (2) When wiring the control circuit, use shielded wires or twisted pair cables.
- (3) Because all of the control terminals except FLA, FLB and FLC are connected to electronic circuits, insulate these terminals to prevent them from coming into contact with the main circuit.

Installing an Thermal relay

- (1) The VF-P7 inverter has a built-in overload protection function by means of a thermal relay. However, in the following cases, the thermal relay operation level must be adjusted or an overload relay matching the motor's characteristics must be installed between the inverter and the motor.
 - (a) When using a motor having a rated current value different from that of the equivalent.
 - (b) When driving several motors simultaneously.
- (2) When you want to use a constant-torque Toshiba VF motor together with the VF-P7 inverter, change the inverter's electronic thermal protection characteristics to match those of the VF motor.
- (3) In order to adequately protect a motor used for low-speed operation, we recommend the use of a motor equipped with an embedded thermal relay.

When changing the motor speed

Application to standard motors

Vibration

When a motor is operated with an industrial inverter, it experiences more vibrations than when it is operated by the commercial power supply. The vibration can be reduced to a negligibly level by fixing the motor and machine to the base firmly. If the base is weak, however, the vibration may increase at a light load due to resonance with the mechanical system.

Reduction gear, belt, chain

Note that the lubrication capability of a reducer or a converter used as the interface of the motor and the load machine may be affected at low speeds. When operating at a frequencies exceeding 60 Hz or higher, power transmission mechanisms such as reduction gear, belts and chains, may cause problems such as production of noise, a reduction in strength, or shortening of service life.

Frequency

Before setting the maximum frequency to 60 Hz or higher, confirm that this operating range is acceptable for the motor.

Application to special motors

Braking motor

When using a braking motor, if the braking circuit is directly connected to the inverter's output terminals, the brake cannot be released because of the lowered starting voltage. Therefore, when using a braking motor, connect the braking circuit to the inverter's power supply side, as shown in the figure below. Usually, braking motors produce larger noise in low speed ranges.

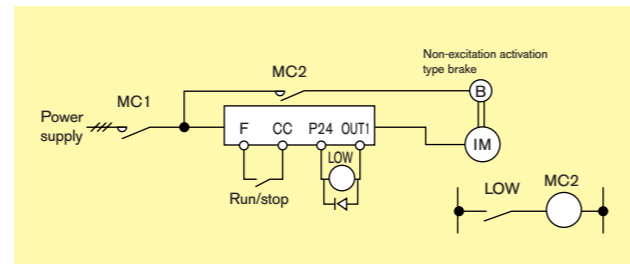

Gear motor

When using an industrial inverter to drive a gear motor, inquire of the motor manufacturer about its continuous operation range, since low-speed operation of a gear motor may cause insufficient lubrication.

Toshiba Gold Motor (High-efficiency power-saving motor)

Inverter-driven operation of Toshiba Gold Motors is the best solution for saving energy. This is because these motors have improved efficiency, power factor, and noise/vibration reduction characteristics when compared to standard motors.

Pole-changing motor

Pole-changing motors can be driven by the VF-P7 inverter. Before changing poles, however, be sure to let the motor come to a complete stop.

High-pole-count motors

Note that high-pole count motors (8 or more poles), which may be used for fans, etc., have higher rated current than 4-pole motors.

The current ratings of multipole motors are relatively high. So, when selecting an inverter, you must pay special attention to its current rating so that the current rating of the motor is below that of the inverter.

Single-phase motor

Because single-phase motors are equipped with a centrifugal switch and capacitors for starting, they cannot be driven by an inverter. If only a single-phase, a 3-phase motor can be driven by using a single-phase input inverter to convert it into a 3-phase 200V output. (A special inverter and a 3-phase motor are required.)

When studying how to use our inverters

Notes

Leakage current

The VF-P7 series of inverters uses high-speed switching devices for PWM control. When a relatively long cable is used for power supply to an inverter, current may leak from the cable or the motor to the ground because of its capacitance, adversely affecting the peripheral equipment. The intensity of such a leakage current depends on the PWM carrier frequency, the lengths of the input and output cables, etc., of the inverter. To prevent current leakage, it is recommended to take the following measures.

[Effects of leakage current]

Leakage current which increases when an inverter is used may pass through the following routes:

- Route (1) ... Leakage due to the capacitance between the ground and the noise filter
- Route (2) ... Leakage due to the capacitance between the ground and the inverter
- Route (3) ... Leakage due to the capacitance between ground and the cable connecting the inverter and the motor
- Route (4) ... Leakage due to the capacitance of the cable connecting the motor and an inverter in another power distribution line
- Route (5) ... Leakage through the grounding line common to motors
- Route (6) ... Leakage to another line because of the capacitance of the ground

Leakage current which passes through the above routes may cause the following trouble.

- Malfunction of a leakage circuit breaker in the same or another power distribution line
- Malfunction of a ground-relay installed in the same or another power distribution line
- Noise produced at the output of an electronic device in another power distribution line
- Activation of an external thermal relay installed between the inverter and the motor, at a current below the rate current

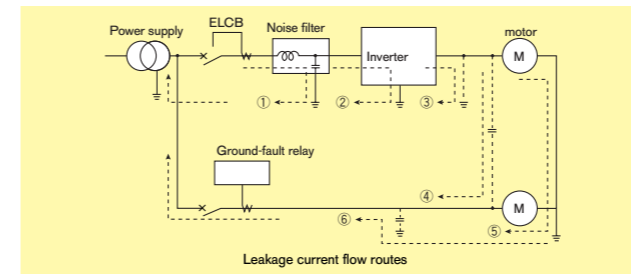

[Measures against effects of leakage current]

The measures against the effects of leakage current are as follows:

- 1) Measures to prevent the malfunction of leakage circuit breakers
 - (1) Decrease the PWM carrier frequency of the inverter. In the case of the VF-P7, the frequency can be decreased up to 0.5kHz. (*)
 - (2) Install leakage circuit breakers (ELCB) with a high-frequency protective function (e.g., Toshiba Mighty series of breakers) in both the same and the other power distribution lines. This makes it possible to operate the VF-P7 with its PWM carrier frequency set high.
- 2) Measures against malfunction of ground-fault relay
 - (1) Decrease the PWM carrier frequency of the inverter. In the case of the VF-P7, the frequency can be decreased up to 0.5kHz. (*)
 - (2) Install ground-fault relays with a high-frequency protective function (e.g., Toshiba CCR1.2 type of relays) in both the same and other lines. This makes it possible to operate the VF-P7 with its PWM carrier frequency set high.
- 3) Measures against noise produced by other electric and electronic systems
 - (1) Separate the grounding line of the inverter from that of the affected electric and electronic systems.
 - (2) Decrease the PWM carrier frequency of the inverter. In the case of the VF-P7, the frequency can be decreased up to 0.5kHz. (*)
- 4) Measures against malfunction of external thermal relays
 - (1) Remove the external thermal relay and use the electronic thermal function of the inverter instead of it. (Unapplicable to cases where a single inverter is used to drive more than one motor. Refer to the instruction manual for measures to be taken when thermal relays cannot be removed.)
 - (2) Decrease the PWM carrier frequency of the inverter. In the case of the VF-P7, the frequency can be decreased up to 0.5kHz.

(Note) Reducing the carrier frequency causes an increase in the magnetic noise caused by the motor.

5) Measures by means of wiring and grounding

- (1) Use a grounding wire as large as possible.
- (2) Separate the inverter's grounding wire from that of other systems or install the grounding wire of each system separately to the grounding point.
- (3) Ground (shield) the main circuit wires with metallic conduits.

(*) The PWM carrier frequency should not be decreased below 2.2kHz in the vector control mode.

Ground fault

Before beginning operation, thoroughly check the wiring between the motor and the inverter for incorrect wiring or short circuits. Do not ground the neutral point of any star-connected motor.

Radio interference

[Noise produced by inverters]

Since the VF-P7 series of inverters performs PWM control, it produces noise and sometimes affects nearby instrumental devices, electrical and electronic systems, etc. The effects of noise greatly vary with the noise resistance of each individual device, its wiring condition, the distance between it and the inverter, etc.

[Measures against noises]

According to the route through which noise is transmitted, the noises produced by an inverter are classified into transmission noise, induction noise and radiation noise.

[Examples of protective measures]

- Separate the power line from other lines, such as weak-current lines and signal lines, and install them apart from each other.
- Install a noise filter in each inverter. It is effective for noise prevention to install noise filters in other devices and systems, as well.
- Shield cables and wires with grounded metallic conduits, and cover electronic systems with grounded metallic cases.
- Separate the power distribution line of the inverter from that of other devices and systems.
- Install the input and output cables of the inverter apart from each other.
- Use shielded twisted pair wires for wiring of the weak-current and signal circuits, and always ground one of each pair of wires.
- Ground the inverter with grounding wires as large and short as possible, separately from other devices and systems.

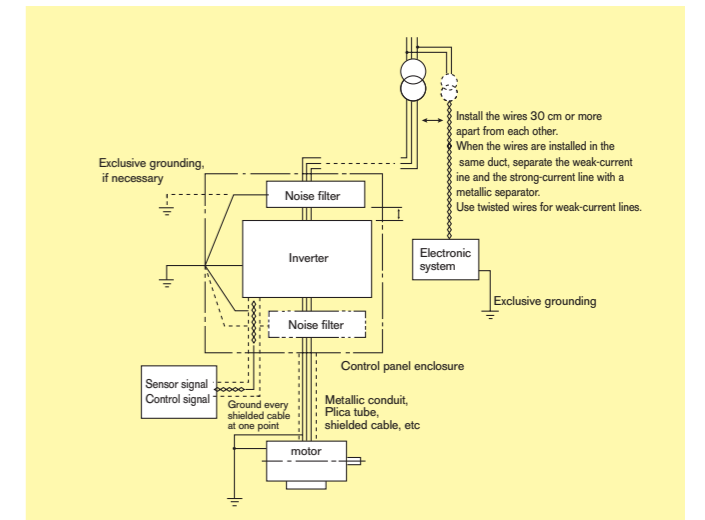

Power factor improvement capacitors

Do not install a power factor improvement capacitors on the input or output side of the inverter.

Installing a power factor improvement capacitor on the input or output side causes current containing harmonic components to flow into the capacitor, adversely affecting the capacitor itself or causing the inverter to trip. To improve the power factor, install an input AC reactor or a DC reactor (optional) on the primary side of the inverter.

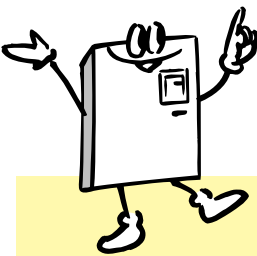

Application and functions of options

Selecting the capacity (model) of the inverter

Selection

Capacity

Refer to the applicable motor capacities listed in the standard specifications. When driving a high-pole motor, special motor, or multiple motors in parallel, select such an inverter that the sum of the motor rated current multiplied by 1.05 to 1.1 is less than the inverter's rated output current value.

Acceleration/deceleration times

The actual acceleration and deceleration times of a motor driven by an inverter are determined by the torque and GD^2 of the load, and can be calculated by the following equations.

The acceleration and deceleration times of an inverter can be set individually. In any case, however, they should be set longer than their respective values determined by the following equations.

	SI unit system	Conventional unit system (for reference)
Acceleration time	$t_a = \frac{(J_m + J_l) \times \Delta N}{9.56 \times (T_u - T_L)} \text{ (sec.)}$	$t_a = \frac{(GD^2_m + GD^2_l) \times \Delta N}{375 \times (T_u - T_L)} \text{ (sec.)}$
Deceleration time	$t_d = \frac{(J_m + J_l) \times \Delta N}{9.56 \times (T_a + T_L)} \text{ (sec.)}$	$t_d = \frac{(GD^2_m + GD^2_l) \times \Delta N}{375 \times (T_a + T_L)} \text{ (sec.)}$
Conditions	J_m : Moment of inertia of motor (kg·m ²) J_l : Moment of inertia of load (kg·m ²) (converted into value on motor shaft) ΔN : Difference in rotating speed between before and after acc. or dec. (min. ⁻¹) T_L : Load torque (N·m) T_u : Motor rated torque x 1.2-1.3 (N·m) ... V/f control Motor rated torque x 1.5 (N·m) ... Vector operation control T_a : Motor rated torque x 0.2 (N·m) (When a braking resistor or a braking resistor unit is used: Motor rated torque x 0.8-1.0 (N·m))	GD^2_m : Motor GD2 (kg·m ²) (converted into value on motor shaft) GD^2_l : Load GD2 (kg·m ²) ΔN : Difference in rotating speed between before and after acc. and dec. (rpm) T_L : Load torque (kg·m) T_u : Motor rated torque x 1.2-1.3 (N·m) ... V/f control Motor rated torque x 1.5 (kg·m) ... Vector operation control T_a : Motor rated torque x 0.2 (kg·m) (When a braking resistor or a braking resistor unit is used: Motor rated torque x 0.8-1.0 (kg·m))

Allowable torque characteristics

When a standard motor is combined with an inverter to perform variable speed operation, the motor temperature rises slightly higher than it normally does during commercial power supply operation. This is because the inverter output voltage has a sinusoidal (approximate) PWM waveform. In addition, the cooling becomes less effective at low speed, so the torque must be reduced according to the frequency. When constant-torque operation must be performed at low speeds, use a Toshiba VF motor designed specifically for use with inverters.

Starting characteristics

When a motor is driven by an inverter, its operation is restricted by the inverter's overload current rating, so the starting characteristic is different from those obtained from commercial power supply operation. Although the starting torque is smaller with an inverter than with the commercial power supply, a high starting torque can be produced at low speeds by adjusting the V/f pattern torque boost amount or by employing vector control. (200% in sensorless control mode, though this rate varies with the motor characteristics.) When a larger starting torque is necessary, select an inverter with a larger capacity and examine the possibility of increasing the motor capacity.

Installation of input AC reactors

These devices are used to improve the input power factor and suppress high harmonic currents and surges. Install an input AC reactor when using a VF-P7 inverter under the following conditions:

- (1) When the power source capacity is 500kVA or more, and when it is 10 times or more greater than the inverter capacity.
- (2) When the inverter is connected the same power distribution system as a thyristor-committed control equipment.
- (3) When the inverter is connected to the same power distribution system as that of distorted wave-producing systems, such as arc furnaces and large-capacity inverters.

Standard replacement intervals of main parts

The table below lists standard component replacement intervals under normal operating conditions (i.e., average year round ambient temperature of 30°C, load ratio of 80% or less, average operation time of 12 hours/day). The replacement intervals do not indicate the service life of each component, but the number of years beyond which the failure rate of a component used without being replaced increases sharply because of deterioration and wear.

Component name	Standard replacement intervals	Replacement method, etc.
Cooling fan	2 to 3 years	Replaced with a new one
Smoothing capacitor	5 years	Replaced with a new one (upon examination)
Contactors, relay	—	Decided upon examination
Fuse	10 years	Replaced with a new one
Aluminum capacitors on the	5 years	Replaced with a new circuit board (upon examination)

Extract from "Periodic Inspection of General-purpose Inverters" published by the Japan Electrical Manufacturers' Association

Note: The service life of each component greatly varies with its usage environment.

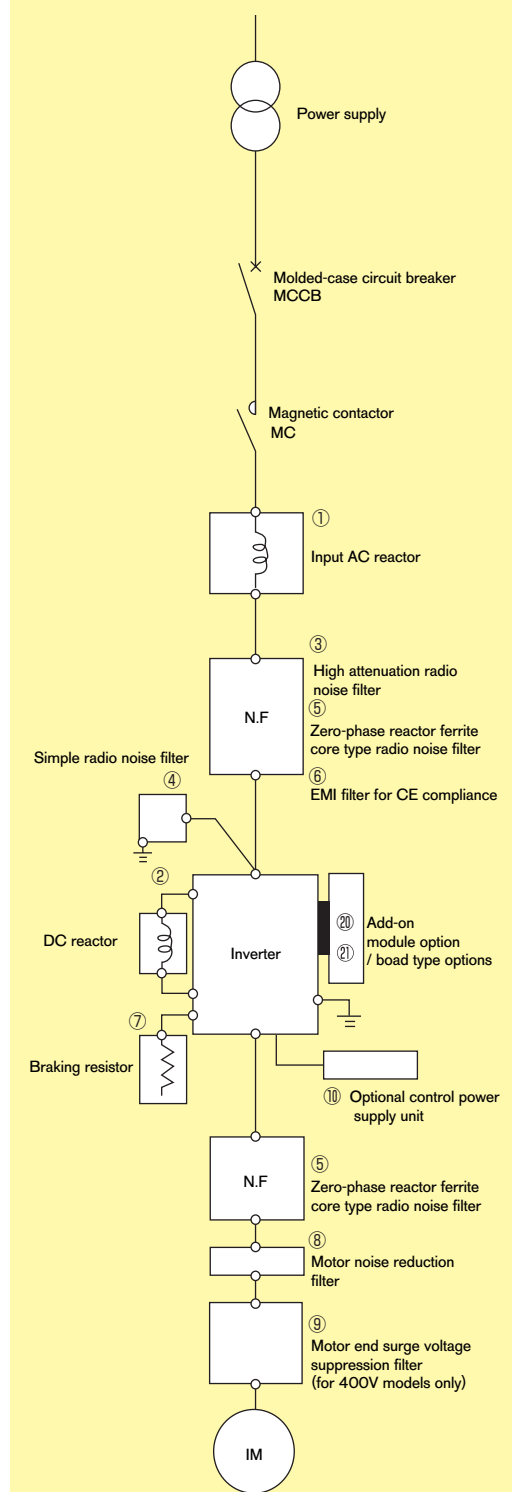

No.	Name	Function, purpose								
①	Input AC reactor	Improves the input power factor, reduces higher harmonics, and suppress external surge on the inverter power supply. Install when the power supply capacity is 500kVA or more and exceeds 10 times the inverter capacity, or when distorted wave-producing systems, such as thyristors and large inverters, are connected to the same power distribution line. To ensure the reactance is effective, contact us because it varies with the impedance.								
②	DC reactor	<table border="1"> <thead> <tr> <th>Reactor</th> <th>Effect</th> </tr> </thead> <tbody> <tr> <td>Input AC reactor</td> <td>Power factor improvement effective</td> </tr> <tr> <td>DC reactor</td> <td>Harmonic suppression effective</td> </tr> <tr> <td></td> <td>External surge suppression effective</td> </tr> </tbody> </table>	Reactor	Effect	Input AC reactor	Power factor improvement effective	DC reactor	Harmonic suppression effective		External surge suppression effective
		Reactor	Effect							
Input AC reactor	Power factor improvement effective									
DC reactor	Harmonic suppression effective									
	External surge suppression effective									
	DC reactors improve the power factor more efficiently than input AC reactors. When an inverter is used for a system for which high reliability is required, you should preferably use a DC reactor together with an input AC reactor, because input AC reactors are effective for suppression of external surge.									
③	High-attenuation filter (LC filter)/NF type, manufactured by Soshin Denki Co., Ltd.	<ul style="list-style-type: none"> Effective in preventing radio interference noise to audio equipment installed near the inverter. Installed on the input side of the inverter. Attenuation characteristic is available in a wide range from AM band to 10 MHz. Use this type when equipment vulnerable to noise is installed in the vicinity of the inverter. 								
④	Simple filter (capacitive filter) Capacitor type, manufactured by Malcon Electronics, Co., Ltd.	<ul style="list-style-type: none"> Effective in preventing radio interference noise to audio equipment installed near the inverter. Installed on the input side of the inverter. Attenuation characteristic is available only in a specific frequency band. Effective in suppressing noise in a specific AM Radio station (e.g., weak radio waves in mountainous regions). Increases leakage current because this is a capacitor-based filter. When the power supply is equipped with an ELCB, avoid using too many filters of this type. 								
⑤	Zero-phase reactor (inductive filter) Ferrite core type, manufactured by Soshin Denki Co., Ltd.	<ul style="list-style-type: none"> Effective for preventing radio interference noise to audio equipment installed near the inverter. Effective for noise reduction on both the input and output sides of an inverter. Attenuation characteristic is available in several decibels in a frequency range of AM radio band to 10MHz. 								
⑥	EMI filter for CE compliance by SCHFFNER	Can conform to CE marking, by using this filter and wiring properly.								
⑦	Braking resistor	Used to reduce the deceleration time, for example, when frequent rapid deceleration or stop is required or the load has a large moment of inertia. A resistor designed to consume energy during dynamic braking.								
⑧	Motor noise reduction filter (for large-capacity models only)	Can be used to suppress the magnetic noise from motor. If the reactor is connected, the magnetic noise from the motor can be reduced by several dB to 10dB (A). (Note that the reactor itself produces a low level of magnetic noise.)								
⑨	Motor end surge voltage suppression filter (for 400V models only)	When a voltage PWM control inverter with ultra-high-speed switching devices (e.g., IGBT) is used to drive a general-purpose motor with a rating of 400V or so, a surge voltage depending on the cable length, cable installation method, cable constant, etc., may damage the insulation of motor coils. In such a situation, it is necessary to use a motor with insulation-reinforced coils or install an AC reactor, a surge suppression filter, etc., on the output side of the inverter in order to reduce surge voltage.								
⑩	Optional control power supply unit	<p>For 22kW models and smaller in which control power is supplied by the main circuit power supply unit, there is no need to supply control power through terminal RO or SO. For 22kW models and smaller, use an optional control power supply unit if there is a need to supply control power separately from main circuit power. (30kW and larger models come standard with a control power supply unit.)</p> <p>Installing a control power supply unit (for 22kW models and smaller)</p> <p>To install a control power supply unit, remove the jumper connector (CN21) inside the inverter and then connect an optional connector.</p> <p>Install the control power supply unit near the inverter main unit.</p>								
⑪	Parameter writer	Unit for reading, copying and writing parameters in batch processing (PWU01Z)								
⑫	Extended panel	Extended panel with an LED display, a RUN/STOP key, an UP/DOWN key, a MONITOR key and an ENTER key								
⑬	RS232C converter unit	This unit is used for data communication via a personal computer. It also allows you to change parameters and save and write data by remote control via an interface cable. This communication unit, which supports RS232C standard, can be connected to two inverters at the same time. <ul style="list-style-type: none"> Monitoring function Parameter setting function Command function Additional functions 								
⑭	Cable with a built-in RS232C communication converter (Model:RS20035)	Optional cable with a built-in RS232C communication converter								
⑮	RS485 converter unit (When connected to 2 inverters)	This unit is capable of operating a maximum of 64 inverters via a personal computer. <ul style="list-style-type: none"> Computer link ... By connecting this unit to a host processor or FA computer, you can organize a network for data communication between inverters. Inverter-to-inverter communications ... Using this unit, you can organize a network for transmission of frequency data, which is required for proportional operation of multiple inverters. 								
⑯	Communication cable	Cables for connection of parameter writers, extension operation panels, RS232C communication units, and RS485 communication units. Model: CAB0011 (1 m), CAB0013 (3 m), CAB0015 (5 m)								
⑰	Remote control panel	Equipped with a frequency meter, a frequency setter, and RUN/STOP switches (forward/reverse). (Model: CBVR-7B1)								
⑱	Application control unit	The AP series of control units are available for the VF-P7 to allow it to carry out various types of control.								
⑲	Harmonic suppression converter Power regeneration converter	<ul style="list-style-type: none"> Designed to suppress harmonics and improve the power factor. Units suitable for loads which frequently undergo rapid deceleration or loads which require minus torque. Contact your Toshiba dealer for applicable models and details.								

No.	name	Function, purpose
⑲	Sensor vector control unit (multiple functions)	Allows still more accurate control if used in combination with a sensor-equipped motor. (Speed control, torque control, and positioning control)
	Extended terminal	Useful in adding special functions to the inverter
⑳	S20 communication	Designed for communication with a programmable controller over a field network. This unit allows high-speed communication (2 Mbps) via an optical fiber cable.
	F10M communication	Designed for communication with a programmable controller over a field network. Bus-type data transmission unit which uses shielded twisted pair cables for the data transmission line and is designed specifically for small industry-intended Toshiba inverters for motor drives.
	RS485 converter unit (When connected to 8 inverters.)	This unit is capable of operating a maximum of 256 inverters via PLC or personal computer. (Depend on function of the inverter model.)

No.	name	Function, purpose
㉑	Sensor vector control unit (complementary output/line driver output)	Allows still more accurate control if used in combination with a sensor-equipped motor. (speed control and torque control)

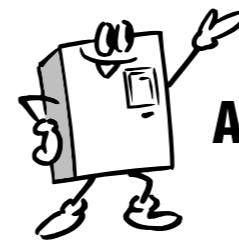

Add-on module/board type options

The following add-on module options and board type options are available for the VF-P7 series of inverters.

Stand-alone options

Voltage class	Applicable motor (kW)	Inverter model	Input AC reactor model	DC reactor model	Radio noise reduction filter			Braking resistor/braking resistor unit model (*3, *4, *5)	Filter for suppressing surge voltage on motor-side model	Motor noise reduction reactor			
					High attenuation type	Simple type	Core type (*1)						
200V	18.5	VFP7-2185P	PFL2100S	DCL-2220	NF3080A-MJ	RC9129	RC9129	PBR3-2150	—				
	22	VFP7-2220P			NF3100A-MJ			PBR3-2220					
	30	VFP7-2300P	PFL2150S	DCL-2370	NF3150A-MJ			PBR-222W002					
	37	VFP7-2370P											
	45	VFP7-2450P	PFL2200S	DCL-2450	NF3200A-MJ			RCL-M2			RC9129	DGP600W-B1 [DGP600W-C1]	NRL2200
	55	VFP7-2550P	PFL2300S	DCL-2550	NF3250A-MJ								
	75	VFP7-2750P	PFL2400S	DCL-2750	NF3200A-MJ Connect 2filters in parallel			RC9129			*6	DGP600W-B1 [DGP600W-C1]	NRL2300
	90	VFP7-2900P	PFL2600S	DCL-2900	NF3250A-MJ Connect 2filters in parallel								NRL2400
110	VFP7-2110KP							*2					
400V	18.5	VFP7-4185P	PFL4050S	DCL-4220	NF3040C-MJ	RC9129	RC9129	PBR3-4150	MSF-4220Z	—			
	22	VFP7-4220P			NF3050C-MJ			PBR3-4220			MSF-4370Z		
	30	VFP7-4300P	PFL4100S	DCL-4450	NF3060C-MJ			PBR-417W008	MSF-4550Z				
	37	VFP7-4370P			NF3080C-MJ								
	45	VFP7-4450P			NF3100C-MJ			MSF-4750Z					
	55	VFP7-4550P	PFL4150S	DCL-4750	NF3150C-MJ								
	75	VFP7-4750P	PFL4300S	DCL-4110K	NF3250C-MJ			RCL-M4	RC9129		*6	DGP600W-B2 [DGP600W-C2]	NRL4155
	90	VFP7-4900P			NF3200C-MJ Connect 2filters in parallel								DGP600W-B3 [DGP600W-C3]
	110	VFP7-4110KP			NF3200C-MJ Connect 2filters in parallel			RC9129	*6		DGP600W-B4 [DGP600W-C4]	NRL4300	
	132	VFP7-4132KP	PFL4400S	DCL-4160K	NF3200C-MJ Connect 2filters in parallel							DGP600W-B3 [DGP600W-C3]	NRL4350
	160	VFP7-4160KP			NF3250C-MJ Connect 2filters in parallel			DGP600W-B4 [DGP600W-C4]	NRL4460				
	200	VFP7-4200KP	PFL4600S	DCL-4220K	NF3250C-MJ Connect 2filters in parallel				DGP600W-B4 [DGP600W-C4]		NRL4550		
	220	VFP7-4220KP			NF3250C-MJ Connect 3filters in parallel			*2					
	280	VFP7-4280KP	PFL4800S	DCL-4280K	NF3250C-MJ Connect 3filters in parallel								
315	VFP7-4315KP												

- Notes)
- *1: The filter needs to be wound 4 turns or more around the power-line (three-phase). (Number of turns: 4 or more) This filter can also be used for the output side of the power line. If the power line consists of electric wires 22 mm² or larger in size, at least four filters must be installed in series. A round type (RC5078) is also available.
 - *2: Contact us for more information.
 - *3: Standard models. Contact us for more information.
 - *4: Models in brackets come standard with a drip cover.
 - *5: To use a 200V/30kW model or larger, or 400V/30kW model or larger in conjunction with an external braking resistor, the inverter must be modified so that a braking resistor circuit can be installed in it.
 - *6: This filter may not be used for some types or sizes of cables.

Name	Type
Option Control power supply unit	CPS0011(200V/400V)
Parameter writer	PWU001Z
Extention panel	RKP001Z
RS232C communication control unit	RS2001Z Computer cable type: CAB0025
Cable with a built-in RS232C communication converter	RS20035
RS485 communication control unit	RS4001Z, RS4002Z
Communication cable	CAB0011(1m), CAB0013(3m), CAB0015(5m)

Table of add-on module/board type options

Table of add-on cassette options

*Use ⑥ attachment for mounting add-on cassette options.

Option	Function/purpose	Type	Remarks (Note 1)
① PG feedback option #1 (Multi-function)	This unit is needed for the PG feedback control. Control modes are speed, torque and positioning.	VEC001Z	Group A
② Extended terminal board option	Required for using the extended terminal function	ETB001Z	
Communication function	③ TOSLINE-S20 option	Required for using TOSLINE-S20	Group B
	④ TOSLINE-F10M option	Required for using TOSLINE-F10M	
⑤ Add-on cassette option attachment	Attachment for mounting add-on cassette options For 75(160)kW and smaller models For 90(200)kW and larger models	SBP001Z SBP002Z	(Note 2)

- Notes)
- 1. The options in group A can be used together. The options in groups A and B can also be used together, but the options in group B cannot be used together with any other option in the same group.
 - 2. () means 400V class.

Table of board type options

Options	Function/purpose	Type	Remarks
PG feed back option#2 (Complimentary output)	This unit is needed for the PG feedback control. Control modes are speed and torque control.	VEC002Z	Cannot use add-on cassette options together
PG feed back option#3 (Line-driver output)		VEC003Z	

Functions of add-on module/board type options

① PG feedback options

Function	Type	VEC001Z	VEC002Z	VEC003Z
Characteristics(Speed/torque)		Speed control:150% torque at 0 speed, control range 1: 1000, precision ±0.02% Torque control:precision ±10%, control range —100% to +100%		
Speed control	Accuracy	Digital:±0.01% Analogue:±0.1%	Digital:±0.01% Analogue:±0.1%	Digital:±0.01% Analogue:±0.1%
	Reference	0 to ±10V, 0 to +10V, 4 to 20mA	0 to ±10V, 0 to +10V, 4 to 20mA	0 to ±10V, 0 to +10V, 4 to 20mA
Torque control	Reference	0 to ±10V, 0 to +10V, 4 to 20mA		
Positioning*	Input pulse	Forward/reverse pulse	Not available	Not available
	Max. pulse freq.	160kpps		
	Electrical gear	100 to 4000 ppr		
PG feed-back method		Line driver :30m Complimentary :100m Open-collector :10m	Complimentary :100m Open-collector :10m	Line driver :30m
PG power source		5/6/12/15V	12V(fixed)	5V(fixed)
Voltage compensation of PG output		Available	Not available	Not available
Breaking detection of sensor cable (during operation)		Available	Available	Available
Breaking detection of sensor cable (during stand-by)		Available	Not available	Not available
±10V analogue reference		Available	Not available	Not available
Programmable output terminal		2 terminal(Sink/source)	Not available	Not available
Alarm signal output		4 terminal(Sink/source)	Not available	Not available

② Extended terminal add-on module options

Function	Description
Contact input	16-bit binary (12-bit binary)
	4-digit BCD (3-digits BCD code)
	Multifunction programmable contact input (higher order 8 bits)
Multifunction programmable analog output (current/voltage switchable)	• Sink logic ON: DC11V and 2.5 mA or more (Max. DC30V) OFF: DC5V or less or 1.4mA or less • Source logic ON: DC5V or less (5mA type) OFF: DC11V or more or 0.5mA or less
Multifunction programmable relay contact output	• Current: DC4-20mA output (source output) Connectable largest resistor: 750 Ω • Voltage: DC+/-10V output • 1a-/1b-contact output (2 circuits) Contact ratings: 250Vac-2A (cos φ = 1) 250Vac-1A (cos φ = 0.4) 30Vdc-1A

- Installation of Add-on module options (200V:75kW or less) (400V:160kW or less)
Connect Add-on cassette option to the right side of VF-P7 via an attachment (SBP001)
1 cassette : 48.5mm and more
2 cassettes : 73.5 //
3 cassettes : 98.5 //

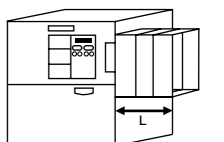

- Installation of Add-on module options (200V:90kW or more) (400V:200kW or more)
Connect Add-on cassette option to the right side of the operating panel via an attachment (SBP002Z)
L=50.0mm and more

