

TYPE RE .444 N

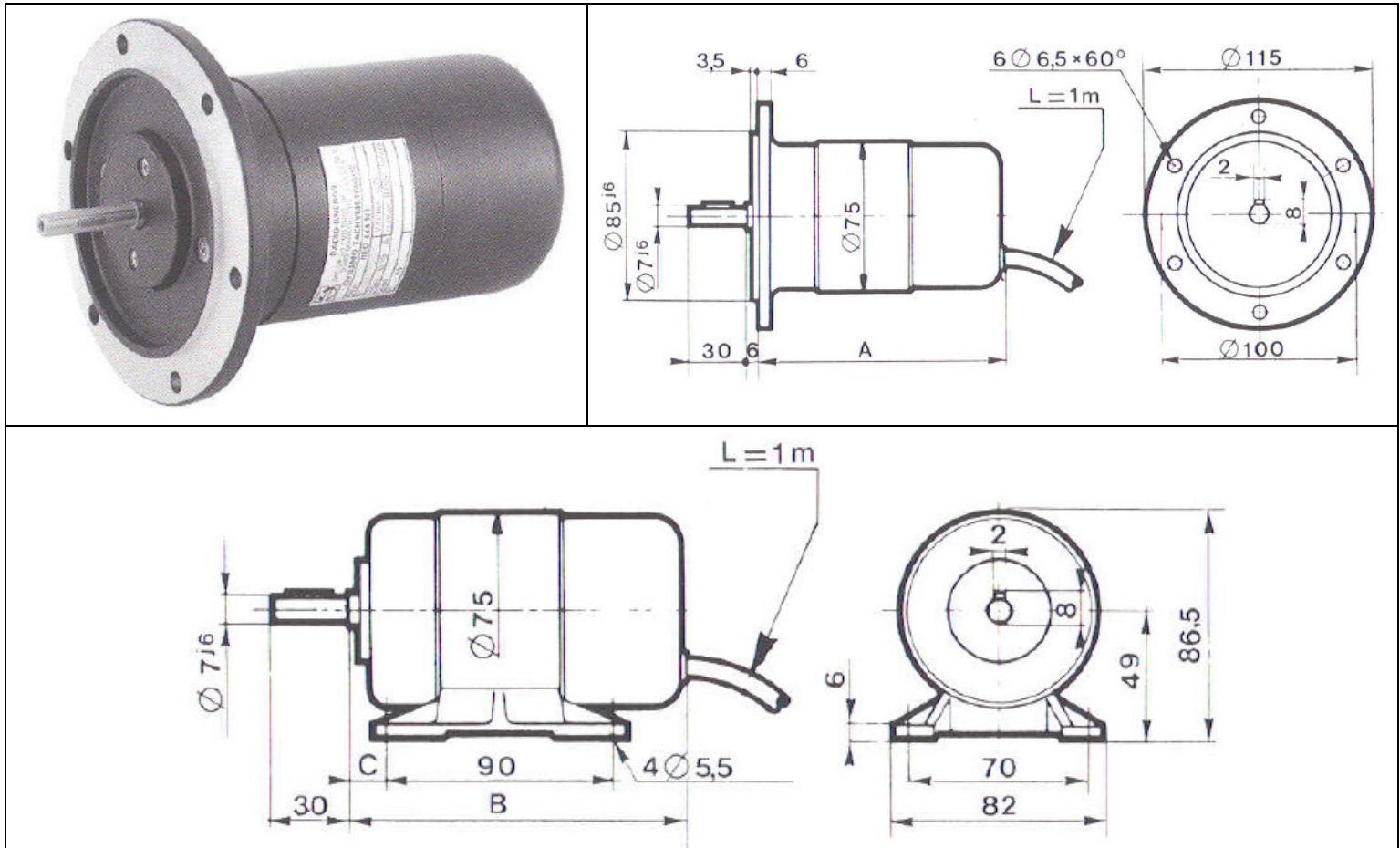

	1 collector	2 collector
$\varnothing 7$	6	6
$\varnothing 11$	6	-
$\varnothing 14$	13	-
$\varnothing 7$	128	144
$\varnothing 11$	131	-
$\varnothing 14$	128	-
$\varnothing 7$	14,5	30,5
$\varnothing 11$	17,5	-
$\varnothing 14$	21,5	-
$\varnothing 7$	134	150
$\varnothing 11$	137	-
$\varnothing 14$	141	-
Weight Kg.	1,8	2,1

GENERAL DATA

Designation	Symb	Unit	Val	
Max. Speed (Mechanical)	n_m	tr/min rpm U/min	12000	
Moment of inertia	J	Kg cm ²	0,950	
No load driving torque	Mr	N.cm	1,50	
Max. radial shaft stress	F	da N	0,4 Ø 7 mm	1,0 Ø 7 mm
Max. E.M.F.	Ern	V	600	
Max. linearity error	ΔE	% Et	$\leq 0,15$	
Overall ripple rate (Peak to Peak)	ΔE_c	% E _C	$\leq 0,5$	
Rotation harmonics (f = 2p.n.)	ΔE_p	% E _C	$\leq 0,2$	
Slot harmonics (f = Z n)	ΔE_z	% E _C	$\leq 0,3$	
Calibration Precision	ΔE_o	% E _{TO}	± 1	
E.M.F. temp drift -- not compensated -- compensated	ΔE_e	% / °C	0,02 0,005	
Time constant	C _t	ms	2,5	
* Filter : Time constant of filter Load Current Speed	$R_f \times R_c$ I _c n	ms mA tr / min rpm U / min	0,47 5 3000	

CONSTRUCTION DETAILS

Number of Poles	2P	2
Number of armature slots	Z	19
Number of collector blades	K	57
Insulation class		B (IEC34 – 1)
Operating temperature		-30° – 130°C
Climatic protection		Ca (IEC68 – 1)
Protection degree		IP 44 (IEC34 – 5)
Direction of rotation : reversible		
Excitation : permanent magnets : Alnico		

We reserve the right to modify technical features in the interest of technological advance.

DESTINATION
<ul style="list-style-type: none"> ○ Industrial application ○ Control and regulation
DESCRIPTION
<ul style="list-style-type: none"> ○ The most common DC Tachometer Generator ○ Permanent magnet excitation ○ Brush holder under cover ○ Cable connection ○ Low ripple ○ Available with one or two commutator

MECHANICAL OPTIONS

SHAFT ENDS AND BEARINGS

	Mounting Side				Opposite Mounting Side		
	D (mm)		L (mm)	Bearings	D (mm)	L (mm)	Bearings
	N1	N2					
Standard	7/11	7	30	8 x 22 x 7ZZ/12 x 28 x 8ZZ	7	30	8 x 22 x 7 ZZ
Max.	14	8	-	15 x 32 x 11 ZZ	8	-	8 x 22 x 7 ZZ

OPTIONS	Sealing cover under (IP -55), flange model Special flange Terminals under cover plate Lateral cable connection
Available options	Second flange

MARKINGS AND POLARITY OF TERMINALS FOR COUNTER-CLOCKWISE ROTATION VIEWING THE MOUNTING FACE

1 collector

2 collectors

White : -
Red : +

Coll. 1

White : +
Red : -

Coll. 2

Green
yellow

ELECTRICAL OPTIONS

				Min									
E.M.F. at 1000 rpm	E_n	V	1 coll. 2 coll.	6	20 2 x 20	30 2 x 30	40	50	60	80	100	120	150
Voltage gradient	C_v	V / tr / min V / rpm V / U / min	1 coll. 2 coll.	0,006	0,020 2 x 0,02	0,030 2 x 0,03	0,040	0,050 2 x 0,05	0,060 2 x 0,06	0,080	0,100 2 x 0,01	0,120	0,150
Armature resistance	R_a	Ω	1 coll. 2 coll.	1,50	12 2 x 24	28 2 x 55	45	70 2 x 150	100 2 x 200	180	280 2 x 470	400	640
Max. thermal load	I_{th}	A	1 coll. 2 coll.	1,40	0,55 2 x 0,23	0,35 2 x 0,14	0,25	0,22 2 x 0,09	0,18 2 x 0,09	0,14	0,11 2 x 0,05	0,09	0,07
Max. thermal load	n_a	tr / min rpm U / min	1 coll. 2 coll.	12000	12000 12000	12000 12000	12000	12000 12000	10000 10000	7500 7500	6000 6000	5000	4000

BRUSHES

No.	Dimensions	Grade	Application Limit	Ref.
	mm	Electro graphite	Standard Maximum output voltage - 600 V	31 - 41 - EG
4	3,1 x 4,1 x 10	Silver Graphite	Recommended for low speed and E.M.F. - < 300 V	31 - 41 - CA