

TYPE RCO E01 R

Module Overspeed switch

DESIGNATION	VALUE	
Switching speed	800 ... 3000 min ⁻¹	
Principle	Centrifugal	
Type of contact	Open or closed	
Moment of inertia	0,102 kg/cm ²	
Rated breaking capacity	5 A / 220 V~	
Maximum breaking capacity	15 A / 220 V~	
Maximum breaking sequence	4/min	
Breaking accuracy	min ⁻¹ ± 5%	
Temperature range	-30 °C - +130 °C	
Protection degree	IP 55	
Weight	0,65 Kg.	

We reserve the right to modify technical features in the interest of technological advance.

General Characteristics

- Robust safety switch module
- Switching speed range from 800 to 3000 rpm
- Terminal box "4 contacts – 2 positions

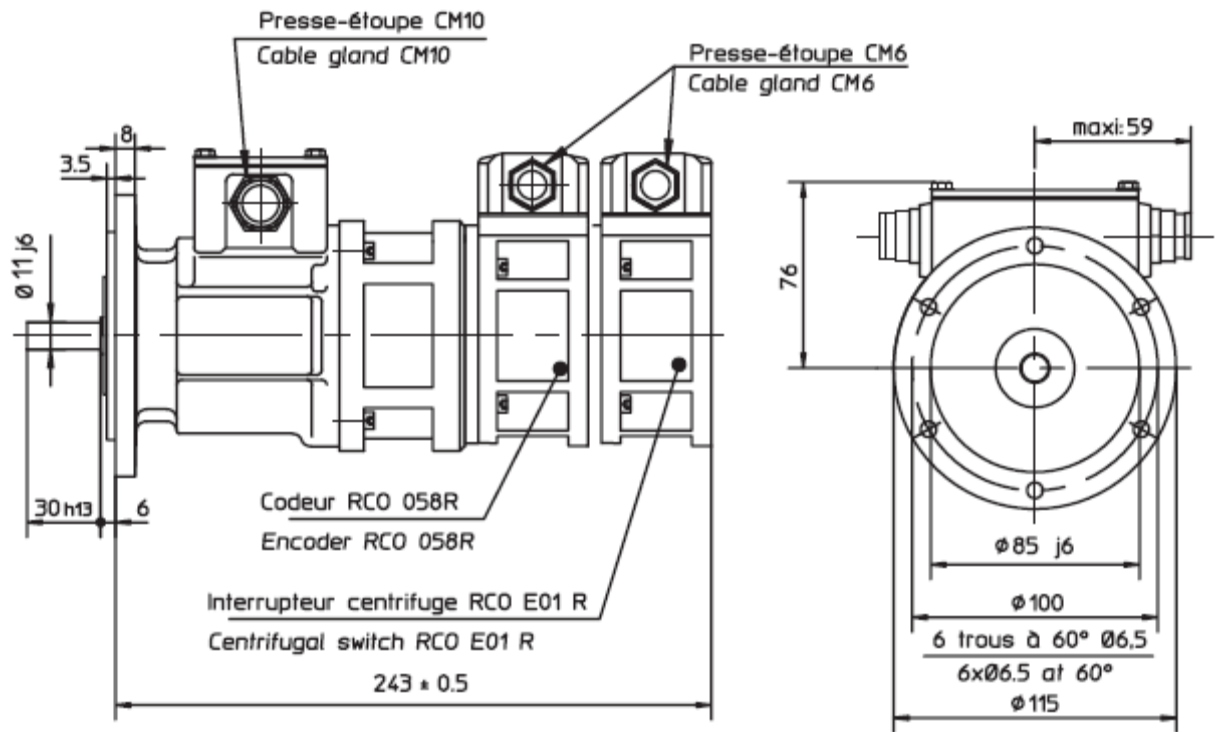

Speed [min ⁻¹]	Hysteresis
800 ... 1000	30 %
1001 ... 1200	23 %
1201 ... 3000	16 %

RCO E01 **R** **X** **XXXX** **BR**

Type

R = Robust version /
Modèle renforcé

O = Position opened / Position "ouvert"
F = Position closed / Position "fermeture"

BR = Radial Terminal box /
Boîte à bornes radiale

XXXX = Switching speed /
Vitesse de déclenchement